

Process Current Data Acquisition

By Shawn MacDonald
DATAQ Instruments, Inc.

One of the most common industrial measurements is process current. Electrical noise, present in most industrial settings, makes measuring a sensor/transducer output as a voltage impractical—especially over long distances. The solution is to transmit the sensor/transducer output as a current signal (process current). This is achieved by placing a resistor (typically 250 Ohms) in series with the sensor/transducer and power supply (Figure 1).

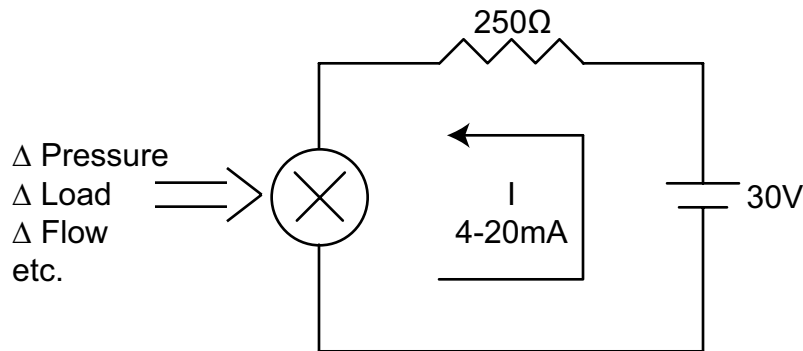

Figure 1

Typical process current loop

Current (I) in the loop is proportional to the change in physical quantity being measured. Using Ohm's law ($V = I \times R$):

If $I = 4\text{mA}$

$$4\text{mA} \times 250\text{ohms} = 1\text{V}$$

If $I = 20\text{mA}$

$$20\text{mA} \times 250\text{ohms} = 5\text{V}$$

Typically, 4mA (1V) represents zero-level while 20mA (5V) represents the full scale output of the sensor/transducer. Since all current leaving the positive side of the battery must return to the negative side, process current is not affected by outside noise.

Hazards to Avoid

Although process current measurements are commonplace and relatively simple to make, there are a couple of sand traps you'll want to avoid.

When measuring process current it's important to consider that a potential difference (common mode voltage) may exist between the loop power supply ground and that of the data acquisition device. To check for such a voltage place a volt meter between the two grounds (Figure 2).

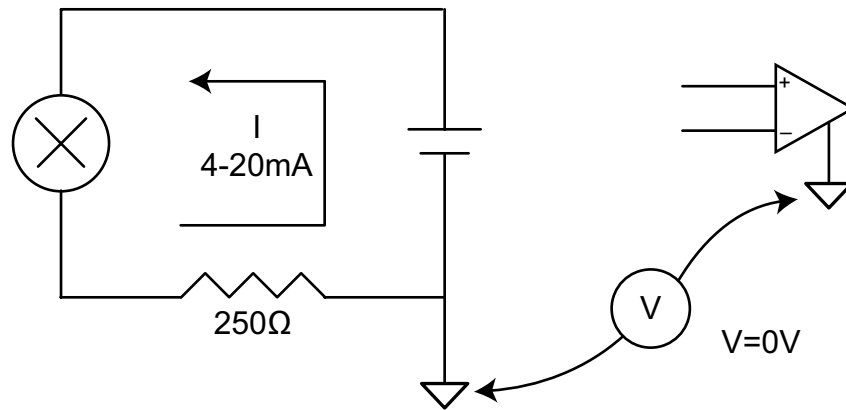

Figure 2

Ideally 0V will be present between the power supply and data acquisition grounds.

Should a common mode voltage (AC or DC) exist, determine the sum of your input signal and the common mode voltage (CMV). If this sum exceeds the maximum rating of your device as specified in the hardware manual you must determine the source of the CMV and eliminate it before taking any measurements. This may be as simple as plugging the loop power supply and data acquisition device into the same wall outlet.

Another common mistake when acquiring process current data is to measure across the shunt resistor on the high side of the current loop. In doing so you're exposing your data acquisition device to the full power supply voltage (Figure 3).

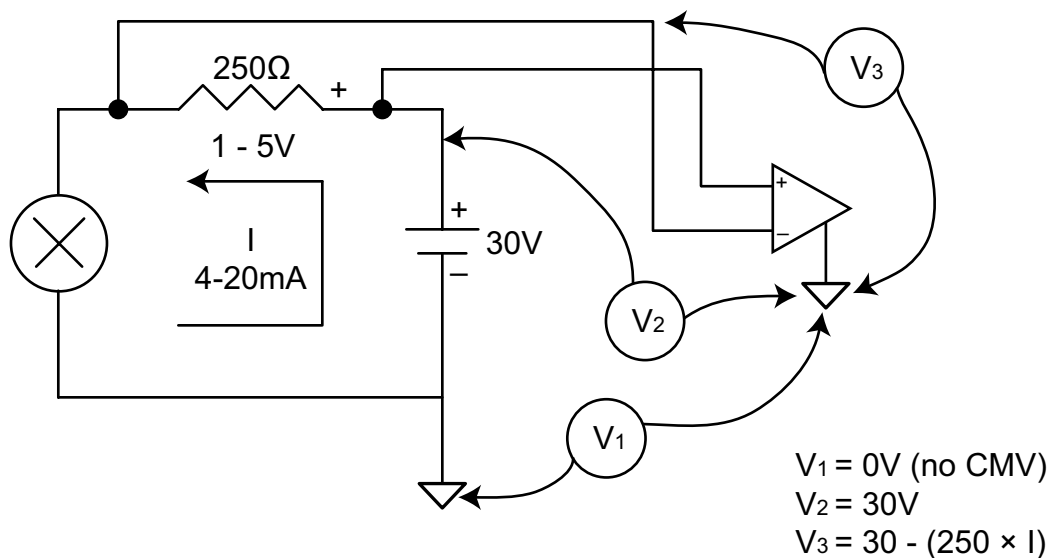

Figure 3

Assuming that the grounds are common, measuring across the shunt resistor on the high side of the circuit exposes the data acquisition device to the power supply voltage.

To avoid this, place the shunt resistor on the low side of the circuit (Figure 4).

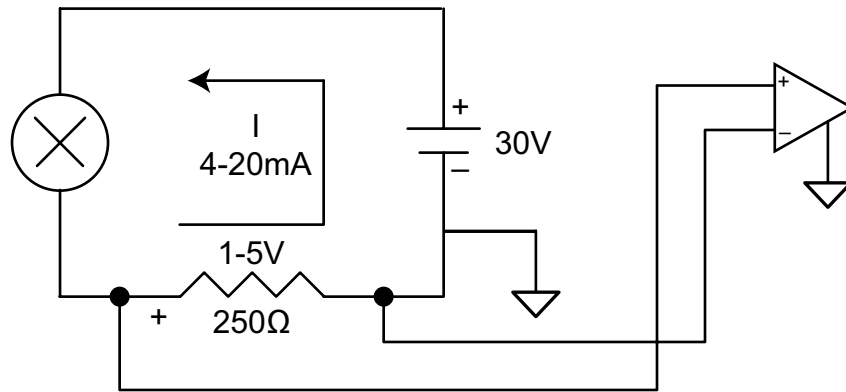

Figure 4

With the shunt resistor on the low side of the circuit the data acquisition device sees only the voltage across the resistor.

This allows you to measure just the voltage across the shunt resistor (1-5V).

The same principles apply to a multi-sensor configuration (Figure 5).

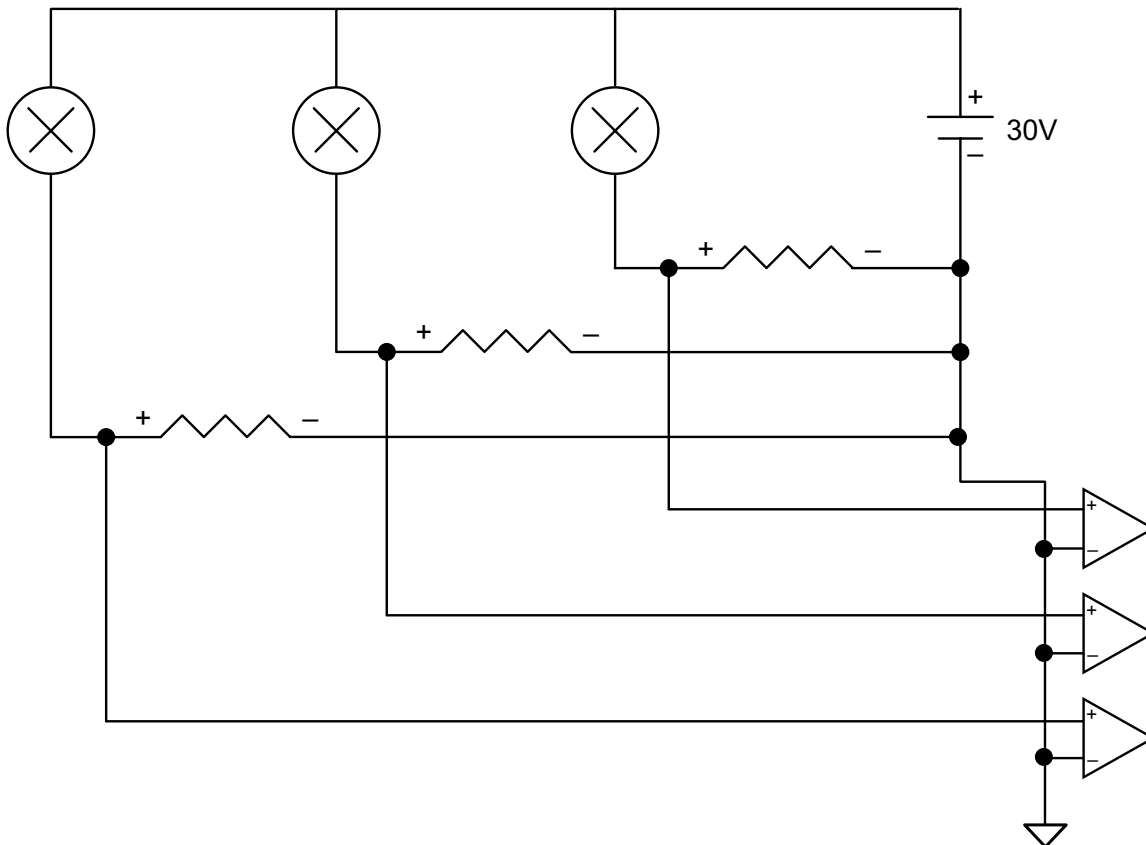

Figure 5

Proper multi-sensor process measurement connections.

Conclusion

With proper precautions, process current measurements can be made with little if any risk to your data acquisition equipment. To eliminate the risk all together consider a data acquisition product that provides isolation (DI-5B32-XX, DI-5B42-XX, DI-8B32-XX, DI-8B42-XX). For more information on isolation see the Application note “Learn the Importance of Isolation in Four Easy Steps” located on our website.