

# DI-5B48 Accelerometer Input Modules

## FEATURES

- ±10V Output Range
- 1500Vrms Transformer Isolation
- ANSI/IEEE C37.90.1 Transient Protection
- Input Protection to 240Vrms Continuous
- 1, 10, and 100 Programmable Gain
- 2.5, 5, 10, and 20kHz Programmable LP Filter
- 0.2 and 10Hz Programmable HP Filter
- 4mA or 9mA Programmable Current Excitation
- ±0.2% Accuracy
- ±0.01% Linearity
- Low Drift with Ambient Temperature
- -40°C to +85°C Operating Temperature
- CSA certification pending
- Mix and Match DI-5B Types

## DESCRIPTION

The DI-5B48 provides excitation to piezoelectric sensors with built-in microelectronic amplifiers, commonly known as ICP®\* or IEPE\* or LIVM\* sensors. The module provides a constant current excitation to the sensor, then isolates, filters, and amplifies the sensor output, yielding a high-level analog voltage output. The excitation current, signal gain, and filter high-pass and low-pass cutoff frequencies are field-configurable through a set of slide switches.

Six poles of signal filtering in the DI-5B48 module result in greater than 100dB of normal-mode rejection for signal frequencies above the cutoff frequency. One pole of filtering is on the field side of the isolation barrier for anti-aliasing purposes and the remaining five-pole programmable Bessel filter is located on the system side. High-pass filtering is achieved through a second order passive filter, located on the field side. If desired, the output switch can be turned on continuously by simply connecting pin 22, the Read-Enable pin, to I/O Common, pin 19.

The DI-5B48 offers the option of setting the constant current source for sensor excitation to common values of 4mA or 9mA with a compliance voltage of 24VDC. Programmable gains of 1, 10 and 100 are selectable and the module offers a ±10V output. The required supply level is +5VDC, ±5%.

To ensure protection of expensive data acquisition equipment, the DI-5B48 module signal inputs and sensor excitation outputs are protected against accidental connection of voltages up to 240Vrms.

## SPECIFICATIONS

Typical at T<sub>A</sub> = +25°C and +5V Power

		DI-5B48
Input Type:		Accelerometer
Input Range:*		±10V
Input Protection	Continuous: Transient:	240Vrms max ANSI/IEEE C37.90.1
Excitation	Constant Current:** Compliance Voltage:	4mA or 9mA, ±10% 24V ±10%
Excitation Protection	Continuous: Transient:	240Vrms max ANSI/IEEE C37.90.1
Output Range:		±10V
Resistance:		50Ω
Protection:		Continuous Short to Ground
Gain (programmable):**		1, 10, 100
CMR (50/60Hz):		100dB
Accuracy:***		±0.2% Span
Linearity:		±0.01% Span
Stability	Offset: Gain:	±25ppm/°C ±100ppm/°C
Output Noise, Gain=1, BW=20kHz:		200μVrms
Low Pass Filter	Type: Programmable:**	Bessel 2.5kHz, 5kHz, 10kHz, 20kHz
High Pass Filter (programmable):**		DC, 0.2Hz, 10Hz
CMV (Input to Output)	Continuous: Transient:	1500Vrms max ANSI/IEEE C37.90.1
NMR:		100db per Decade above cutoff frequency
Supply Voltage:		+5VDC ±5%
Current:		140mA (9mA excitation) 100mA (4mA excitation)
Mechanical Dimensions		2.28" × 2.26" × 0.60" (58mm × 57mm × 15mm)
Environmental	Operating Temperature Storage Temperature	-40°C to +85°C -40°C to +85°C
* AC peak for AC coupling. For DC coupling input range (AC + DC): 0 to +10V. ** Programmable using slide switches on the bottom of the module. *** Includes linearity, repeatability and hysteresis.		

# DI-5B48 Accelerometer Input Modules

## Block Diagram

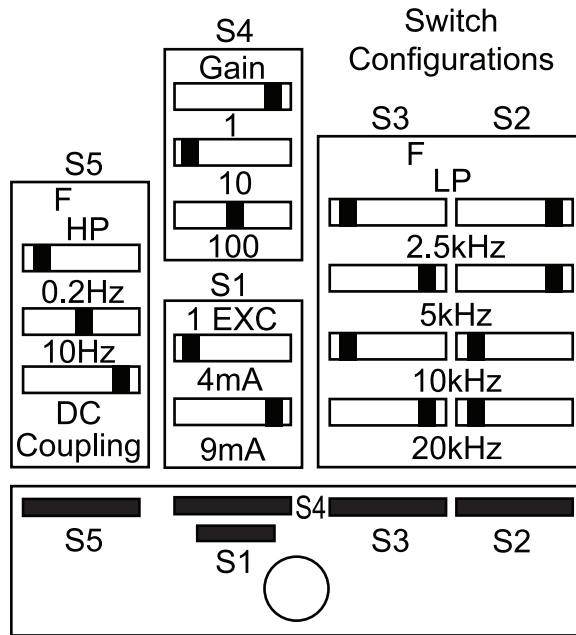
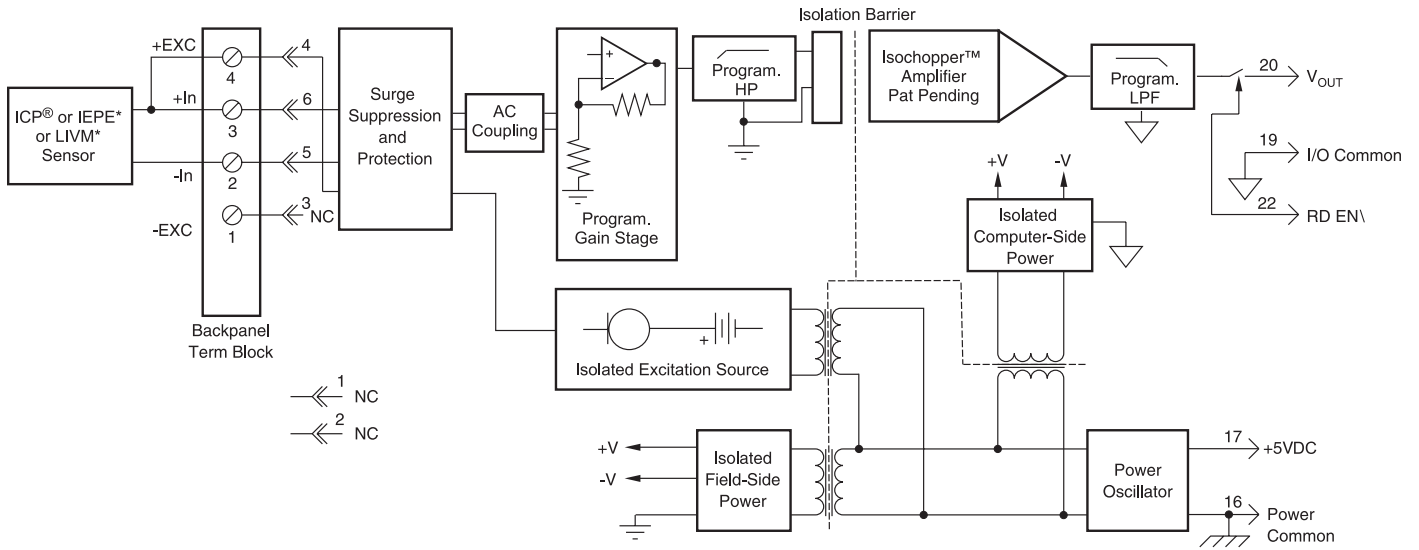

Bottom View

## Ordering Information

Model Number	Input Range	Output Range	Bandwidth	Isolation Voltage
DI-5B48-01	±10V max	±10V	2.5kHz to 20kHz	1500



**DATAQ**<sup>®</sup>  
INSTRUMENTS

241 Springside Drive  
Akron, Ohio 44333  
330-668-1444

### Data Acquisition Product Links

(click on text to jump to page)

[Data Acquisition](#) | [Data Logger](#) | [Chart Recorder](#) | [Thermocouple](#) | [Oscilloscope](#)

The information on this data sheet is subject to change without notice.

DATAQ and the DATAQ logo are registered trademarks of DATAQ Instruments, Inc. All rights reserved. Copyright © 2008 DATAQ Instruments, Inc.