

## ***DI-900MB Series Modbus/RS485 Network I/O Modules***

***Model DI-913MB***  
*Quad DC Current Input*

***Model DI-914MB***  
*Quad DC Voltage Input*

## ***User's Manual***

Copyright © 2003 by DATAQ Instruments, Inc. The Information contained herein is the exclusive property of DATAQ Instruments, Inc., except as otherwise indicated and shall not be reproduced, transmitted, transcribed, stored in a retrieval system, or translated into any human or computer language, in any form or by any means, electronic, mechanical, magnetic, optical, chemical, manual, or otherwise without expressed written authorization from the company. The distribution of this material outside the company may occur only as authorized by the company in writing.

DATAQ Instruments' hardware and software products are not designed to be used in the diagnosis and treatment of humans, nor are they to be used as critical components in any life-support systems whose failure to perform can reasonably be expected to cause significant injury to humans.

Windows 95/98 & NT are registered trademarks of Microsoft Corporation. Modbus is a registered trademark of Modicon, Inc.



241 Springside Dr., Suite #200  
Akron, Ohio 44333 U.S.A.  
Telephone: 330-668-1444  
Fax: 330-666-5434

Designed and manufactured in the  
United States of America



# Warranty and Service Policy

## Product Warranty

DATAQ Instruments, Inc., warrants the instruments described in this manual to be free from defects in materials and factory workmanship to the original buyer. This warranty is contingent upon proper use of the equipment, and does not cover equipment that has been modified or has been subjected to abusive physical or electrical stresses. DATAQ Instruments, Inc., agrees to repair or replace, at its sole discretion, any instrument that fails to perform as specified within 18 months after date of the original shipment from the factory, or 12 months after the date of installation, whichever date comes first.

DATAQ Instruments, Inc., reserves the right to make substitutions and modifications in the specifications of equipment that do not materially or adversely affect the performance of the equipment.

New equipment may be returned within 30 days of shipment with prior factory approval and upon the assignment of a Returned Material Authorization number, RMA number, by DATAQ Instruments, Inc. This number must be clearly shown on the return package(s). RMA numbers are valid for 30 days from date of issue. New items in factory sealed containers which are less than thirty days old after shipment may be returned for credit, less a minimum restocking and testing charge of twenty percent of the list price upon factory approval only, provided the customer pays all shipping and handling charges. Specially ordered, or modified goods, or goods which have been used or have been unpacked from the factory-sealed containers, or goods which have been shipped more than thirty days prior are not returnable.

The information contained in this manual is subject to change without notice. DATAQ Instruments, Inc., makes no warranty of any kind with regard to this material, including, but not limited to, the implied warranties of merchantability and fitness for a particular purpose. Further, DATAQ Instruments, Inc., assumes no responsibility for any errors that may appear in this manual and makes no commitment to update, or keep current, the information contained in this manual.

## Service Policy

Units within the warranty period returned for repair, test, and recalibration are serviced at no charge in accordance with the terms of the warranty policy. The Customer pays all transportation and other charges to the factory.

Units out of warranty returned for repair, test, and/or recalibration are handled on a time and material basis. If requested, or if costs exceed 50% of current list price, DATAQ Instruments, Inc., advises the customer prior to making the repairs. Such repairs are performed at the customer's expense. Typical test, recalibration, and repairs are 25% of the instrument's current list price. Transportation charges both ways are at the customer's expense.

Please be sure all returns are shipped with the following information included:

1. "Returned Material Authorization," RMA number, clearly shown on each package. Please call DATAQ Instruments, Inc., at 330-668-1444 to obtain your RMA number.
2. Your company Name with Billing and Shipping Addresses.
3. A complete description of your problem, or re-calibration data.
4. The contact person at your company, with their telephone and facsimile numbers.
5. Non-Warranty returns additionally need your Purchase Order Number.

Please pack your returned instruments in their original shipping cartons, or in equivalent strong protective shipping cartons.

## **Service and Repair Assistance**

This module contains solid-state components and requires no maintenance, except for periodic cleaning and transmitter configuration parameter (zero, full-scale, setpoint, deadband, etc) verification. Since Surface Mount Technology (SMT) boards are generally difficult to repair, it is highly recommended that a non-functioning module be returned to DATAQ Instruments Inc., for repair. The board can be damaged unless special SMT repair and service tools are used. Further, DATAQ Instruments, Inc., has automated test equipment that thoroughly checks and calibrates the performance of each module. Please contact DATAQ Instruments, Inc., for complete details on how to obtain service parts and repair.

**CAUTION:** Risk of Electric Shock - More than one disconnect switch may be required to de-energize the equipment before servicing.

## **Preliminary Service Procedure**

Before beginning repair, be sure that all installation and configuration procedures have been followed. Make sure that the correct baud rate is selected for the RS232-to-RS485 converter employed. The unit routinely performs internal diagnostics following power-up or reset. During this period, the green "Run" LED flashes.

If the diagnostics complete successfully, the "Run" LED will stop flashing after two seconds and remain ON. This indicates that the unit is operating normally. If the "Run" LED continues to flash, then this is indicative of a problem. In this case, use the Modbus Configuration Software to reconfigure the module and this will usually cure the problem. If the diagnostics continue to indicate a problem (a continuously flashing green LED), or if other evidence points to a problem with the unit, an effective and convenient fault diagnosis method is to exchange the questionable module with a known good unit. DATAQ Instruments' Application Engineers can provide further technical assistance if required. When needed, complete repair services are available from DATAQ Instruments, Inc.

## **Safety Summary**



Means "Caution, refer to this manual for additional information."

### **IMPORTANT SAFETY CONSIDERATIONS**

It is very important for the user to consider the possible adverse effects of power, wiring, component, sensor, or software failures in designing any type of control or monitoring system. This is especially important where economic property loss or human life is involved. It is important that the user employ satisfactory overall system design. It is agreed between the Buyer and DATAQ Instruments, Inc., that this is the Buyer's responsibility.

---

# Table of Contents

<b>Warranty and Service Policy .....</b>	<b>iii</b>
<b>1. Introduction .....</b>	<b>1</b>
Description .....	1
Key DI-913MB/DI-914MB Module Features: .....	2
<b>2. Specifications .....</b>	<b>5</b>
General .....	5
Model Number Definition .....	5
Analog Input Specifications .....	5
Digital Output Specifications .....	6
Enclosure/Physical Specifications .....	6
Approvals (-xxx0) .....	7
Environmental Specifications .....	7
Communication Interface Specifications .....	8
Configuration and Controls .....	9
Software Configuration .....	10
Other Modbus Configuration Software Capabilities .....	12
<b>3. Getting Started .....</b>	<b>13</b>
Unpacking and Inspection .....	13
Module Installation .....	13
Default Mode Switch .....	14
Mounting .....	14
Electrical Connections .....	14
Software Installation—Using Setup.exe .....	15
<b>4. Module Configuration .....</b>	<b>17</b>
Register Map .....	17
<b>5. An Introduction to Modbus .....</b>	<b>27</b>
Remote Terminal Unit (RTU) Mode .....	27
Modbus Message Framing .....	27
How Characters Are Transmitted Serially .....	28
Modbus Addresses .....	28
Modbus Functions .....	28
Read Coil Status (01) .....	29
Read Holding Registers (03) .....	30
Read Input Registers (04) .....	30
Force Single Coil (05) .....	31
Preset Single Register (06) .....	31
Force Multiple Coils (15) .....	32
Preset Multiple Registers (16) .....	33
Report Slave ID (17) .....	33
Reset Slave (08) .....	34
Modbus Data Field .....	35
Supported Data Types .....	35
Modbus Error Checking Fields .....	35
Parity Checking .....	35
CRC Error Checking .....	36

Modbus Exceptions .....	36
<b>6. Module Software Configuration .....</b>	<b>39</b>
Before You Begin .....	39
Starting The Program .....	40
File .....	40
Module .....	40
Settings .....	40
Help .....	41
Creating A Configuration File .....	41
Module .....	41
Alarm Configuration .....	43
Alarm Config Field Descriptions .....	43
Writing Your Configuration .....	44
Module .....	44
Testing Your Configuration .....	44
Test Operation .....	44
Print Your Configuration .....	45
Saving Your Configuration .....	45
Module Calibration .....	46
Module Input Calibration .....	46
<b>7. Block Diagrams and Schematics .....</b>	<b>49</b>
Theory of Operation .....	49
Simplified Schematic (4501-853) .....	49
Functional Block Diagram (4501-854) .....	50
Network Connections (4501-805) .....	50
Electrical Connections (4501-855) .....	51
Interposing Relay Conn. & Contact Pro. (4501-856) .....	51
Enclosure Dimensions (4501-857) .....	52
<b>8. Accessories .....</b>	<b>53</b>
Series DI-900MB Software Interface Package (Model 100969) .....	53
DI-900MB Configuration & Control Software .....	53
RS-232 to RS-485 Serial Adapter .....	53
Interface Cable .....	53
Isolated Signal Converter (Models 100974 and 100975) .....	53
Isolated Network Repeater (Models 100977 and 100978) .....	53
AC Current Sensor (Model 100973) .....	53

# 1. Introduction

These instructions cover the hardware functionality of the transmitter models listed in the table below. Supplementary sheets are attached for units with special options or features.

Models Covered in This Manual		
Series/Input Type	-Options/Output/Enclosure/ Approvals <sup>1</sup>	-Factory Configuration <sup>2</sup>
DI-913MB	-0900	-C
DI-914MB	-0900	-C

Notes:

1. Agency approvals include CE, UL Listed, and cUL Listed.
2. Include the “-C” suffix to specify factory configuration option. Otherwise, no suffix is required for standard configuration.

The same circuit board used to build the Model DI-924MB is used for these two models. If you are already familiar with the DI-924MB, operation and specifications of the DI-913MB/DI-914MB are similar.

## Description

The DI-900MB family is a group of process I/O modules and accessories for Modbus/RS485 network I/O applications. The Model DI-913MB will condition up to four channels of DC current signals, and provide an isolated RS485 network I/O path utilizing the industry standard Modbus protocol. The Model DI-914MB will condition up to four channels of DC voltage signals, and provide an isolated RS485 network I/O path utilizing the industry standard Modbus protocol. Both models also include four control outputs for high/low limit alarm support, or for simple ON/OFF control of external devices. The DI-913MB/DI-914MB contains an advanced technology microcontroller with integrated downloadable flash memory and EEPROM for non-volatile program, configuration, calibration, and parameter data storage. Units are fully reconfigurable via our user-friendly Windows 95/98<sup>®</sup> or NT<sup>®</sup> Configuration Program and the RS485 interface. Once configured, these modules may operate as an active RS485 network slave connected to other modules and a host computer.

Each module provides four isolated analog inputs of either DC current (DI-913MB) or DC voltage (DI-914MB). The modules use a high resolution, optically-isolated, low noise, Sigma-Delta Analog to Digital Converter ( $\Sigma\Delta$  ADC) to accurately convert the input signals into digitized values. Inputs include high/low alarm functionality with open-drain alarm output switches. These output channels include a yellow LED on the front of the module that provides visual indication of its state and/or alarm condition. Additionally, a green “Run” and yellow “Status” LED provide local feedback of operating mode, system diagnostics, watchdog timeout, and module status.

All DI-900MB modules are designed to withstand harsh industrial environments. They feature RFI, EMI, ESD, EFT, and surge protection, plus low temperature drift, wide ambient temperature operation, and isolation between signal I/O, power, and the network. They also have low radiated emissions per CE requirements. As a wide-range DC-powered device, the unit may be powered from DC power networks incorporating battery backup. The unit may also be powered from common 24VAC power. Since the input is diode-bridge coupled, the unit may be connected to redundant power supplies, or several units may safely share a single DC supply. Units are DIN-rail mounted and removable terminal blocks facilitate ease of installation and replacement, without having to remove wiring. Transmitter power, network, and digital output wiring are inserted at one side of the unit, while input wiring is inserted at the other side. Plug-in connectors are an industry standard screw clamp type that accept a wide range of wire sizes.

An optional AC current sensor (Model 100973) may be used in conjunction with the DC current input circuit of the Model DI-913MB to implement AC current measurement and alarms for inputs up to 20A rms. The optional AC current sensor is itself an isolated, accurate, toroidal instrument transformer, that outputs a safe, low-level DC milliamp

signal to the input of the alarm. As an isolated device, it may also be used to facilitate input-to-input isolation between inputs of this model. See the AC Current Sensor (Model 100973) section for more information.

Flexible transmitter functionality, network reprogrammability, mixed signal I/O, alarm support, and a network interface, all combine in a single package to make this instrument extremely powerful and useful over a broad range of applications. Further, the safe, compact, rugged, reconfigurable, and reliable design of this transmitter makes it an ideal choice for control room or field applications. Custom module configurations are also possible (please consult the factory).

## Key DI-913MB/DI-914MB Module Features:

- **Agency Approvals** - CE, UL, & cUL Listings pending.
- **Easy Windows<sup>®</sup> Configuration** - Fully reconfigurable via our user-friendly Windows 95/98<sup>®</sup> or NT<sup>®</sup> DI-900MB Configuration Program.
- **RS485/Modbus Network Interface** - This proven high speed interface is highly immune to noise, can operate over long distances, and allows a large number of modules to be networked together. The unit communicates using the industry-standard Modbus command/response protocol.
- **Nonvolatile Reprogrammable Memory** - This module has an advanced technology microcontroller with integrated, non-volatile, downloadable flash memory and EEPROM. This allows the functionality of this device to be reliably reprogrammed thousands of times.
- **Fully Isolated** - Input, outputs, network, and power are all isolated from each other for safety and increased noise immunity. Inputs are also isolated from each other for common mode voltages up to  $\pm 4V$  for increased noise immunity between channels.
- **Discrete or Alarm Outputs** - High voltage, high current, open-drain mosfets provide direct or alarm control of external devices. Outputs may be activated independently, via watchdog timeout, or under alarm control in both failsafe and non-failsafe modes.
- **Flexible Multi-Range Analog Inputs** - Select either DC current or DC voltage input signals according to model.
- **Optional AC Current Input (DI-913MB Only)** - An optional AC current sensor can be purchased separately to support AC current inputs and alarms for this model.
- **Self-Diagnostics** - Built-in routines operate upon power-up for reliable service, easy maintenance, and troubleshooting. A hardware watchdog timer is built into the microcontroller that causes it to initiate a self reset if the controller ever “locks up” or fails to return from an operation in a timely manner.
- **High-Speed Data Rates** - Supports RS485 communication rates up to 115K baud.
- **Wide Ambient Operation** - The unit is designed for reliable operation over a wide ambient temperature range.
- **Wide-Range DC-Power or 24VAC Power** - This device receives power over a wide supply range and the power terminals are diode-bridge coupled. This makes this transmitter useful for systems with redundant supplies, and/or battery back-up. Additionally, the power terminals are not polarized.
- **Watchdog Timer** - An I/O watchdog timer function is included and may be configured for timeout periods up to 65534 seconds (18.2 hours). Timer will timeout if a read or write operation to any I/O channel does not occur over the configured time period. Optionally, outputs may be automatically set to user-defined states following timeout. Watchdog control of output has higher priority than alarm control and direct control.
- **Hardened For Harsh Environments** - The unit will operate reliably in harsh industrial environments and includes protection from RFI, EMI, ESD, EFT, and surges, plus low radiated emissions per CE requirements.
- **Convenient Mounting, Removal, & Replacement** - The DIN-rail mount and plug-in type terminal blocks make module removal and replacement easy.



- **High-Resolution Precise A/D Conversion** - Transmitters include a high-resolution, low noise, Sigma-Delta Analog to Digital Converter ( $\Sigma\Delta$  ADC) for high accuracy and reliability.
- **LED Indicators** - A green LED indicates power. A yellow status LED will turn on if an input signal is out of calibrated range, or it flashes if the unit is placed in the default communication mode. It will also flash rapidly upon watchdog timeout. A yellow output LED indicates the ON/OFF state of the associated open-drain output.
- **Default Communication Mode** - A push-button switch is provided to set the module to a default set of communication parameters for baud rate, module address, parity, and number of stop bits. This provides a convenient way of establishing communication with the module when its internal settings are unknown.
- **Automatic Self-Calibration** - Built-in self-calibration corrects for temperature drift of the input circuit every 60 seconds.
- **Alarm Functionality** - Alarm limit checking is always active for the module. High and/or low limit levels, plus deadband may be configured at each input. Optionally, failsafe or non-failsafe alarm outputs may be enabled for each limit. Alarm control has priority over direct control of an output.
- **Configurable Setpoint With Deadband** - Includes programmable deadband to help eliminate switch “chatter.”



## 2. Specifications

### General

The Model DI-913MB and DI-914MB modules are DC-powered or 24VAC powered network transmitters which condition up to four DC current (DI-913MB), or DC voltage (DI-914MB) input signals, and provide an isolated RS485/Modbus network interface, plus four digital outputs. Isolation is supplied between the sensor inputs, the network, power, and the digital outputs. The open-drain outputs provide alarm control functionality, or may operate as discrete ON/OFF control outputs. This network transmitter is DIN-rail mounted.

The unit is configured and calibrated with our user-friendly Window 95/98<sup>®</sup> or NT<sup>®</sup> DI-900MB Configuration Program. Optionally, you may use your own software as long as you adhere to the Modbus command/response format for supported commands. A push button on the module allows communication with a module when its address, baud rate, and parity settings are unknown. Non-volatile reprogrammable memory in the module stores calibration and configuration information.

### Model Number Definition

Transmitters are color coded with a white label. The prefix “9” denotes the Series 900, while the “MB” suffix specifies that this device is primarily a process transmitter for Modbus networks.

DI-913MB: Transmits and isolates up to four DC current inputs.

DI-914MB: Transmits and isolates up to four DC voltage inputs.

-0900: The four digits of this model suffix represent the following options, respectively:

0 = No Options;

9 = Output: RS485/Modbus;

0 = Enclosure: DIN rail mount;

0 = Approvals (Pending): CE, UL Listed, and cUL Listed.

### Analog Input Specifications

The unit must be wired and configured for the intended input type and range (see Module Installation for details). The unit can be configured to accept any one of the input types described using the Modbus Configuration Program. The following paragraphs summarize this model's input types, ranges, and applicable specifications.

**DC Current (DI-913MB Only)** Configurable for 0 to 20mA, 4-20mA, 0-11.17mA, and 0-1mA DC nominal input ranges. A precision 49.9 $\Omega$  current sink resistor converts the input current to a voltage that is processed by the A/D converter. An optional external sensor is required to monitor AC current signals (Model 100973). This sensor generates a DC milliamper signal of 0 to 11.17mA for the module (see Table 2 for scaling to AC current).

Current Input Reference Test Conditions: 4 to 20mA current input; Ambient Temperature = 25°C.

Input Overvoltage Protection: Bipolar Transient Voltage Suppressors (TVS), 5.2V clamp level typical.

**DC Voltage (DI-914MB Only)** A 10:1 input divider is installed at the input (divider resistor values of 100K and 10.5K). User-configurable for the nominal bipolar DC voltage ranges of  $\pm 10V$ ,  $\pm 5V$ ,  $\pm 2.5V$ ,  $\pm 1.25V$ ,  $\pm 625mV$ ,  $\pm 313mV$ ,  $\pm 156mV$ , and  $\pm 78mV$  DC.

Input Impedance: 110.5K $\Omega$

Voltage Input Reference Test Conditions: -10 to 10V DC Input; Ambient Temperature = 25°C.

Input Overvoltage Protection: Bipolar Transient Voltage Suppressers (TVS), 18V clamp level typical.

### General Input Specifications

Accuracy: Accuracy is better than  $\pm 0.1\%$  of span, typical for nominal input ranges. This includes the effects of repeatability, terminal point conformity, and linearization, but does not include sensor error.

Measurement Temperature Drift: Better than  $\pm 100\text{ppm}/^\circ\text{C}$ .

Analog to Digital Converter (A/D): A 16-bit  $\Sigma\text{-}\Delta$  converter.

Resolution: 0.005% or 1 part in 20000.

Input Conversion Rate: 180ms per channel, or 720ms for all four channels.

Input Filter: Normal mode filtering, plus digital filtering optimized and fixed per input range within the  $\Sigma\text{-}\Delta$  ADC.

Input Filter Bandwidth: -3dB at 3Hz, typical.

Noise Rejection (Normal Mode): 40dB @ 60Hz, typical with 100 $\Omega$  input unbalance.

Noise Rejection (Common Mode): 140dB @ 60Hz, typical with 100 $\Omega$  input unbalance.

### Digital Output Specifications

Four open-drain outputs, one per channel, are installed in this module and provide alarm limit control functionality, or may operate as discrete outputs (coils). Alarm control of the output state will take precedence over direct control and the corresponding alarm should be disabled if direct control is desired. Note that outputs are OFF following a software or power-on reset, but may be optionally set to user-defined states following a watchdog timeout. Watchdog timeout control (timeout state) will have the highest precedence when enabled.

**Note:** To control a higher amperage device, such as a pump, an interposing relay may be used (see Drawing Interposing Relay Conn. & Contact Pro. (4501-856)).

Output Channel Configuration: Four independent, open-drain mosfet switches which share a common return (source) connection at the terminals labeled RTN. For DC voltage and current sinking applications only--observe proper polarity. To control higher voltages and/or currents, or for controlling AC, an interposing relay may be used (see Drawing Electrical Connections (4501-855)).

Output "OFF" Voltage Range: 0 to +35V DC.

Output "OFF" Leakage Current: 0.1 $\mu\text{A}$  typical, 50 $\mu\text{A}$  maximum (25°C, 40VDC).

Output "ON" Current Range: 0 to +1A DC, continuous, for each output switch (group one RTN per each group of 2 outputs). No deration is required at elevated ambient temperatures.

Output  $R_{ds}$  ON Resistance: 0.15 $\Omega$  Maximum (25°C, 1A).

Output Response Time: 4.1ms, typical, measured from receipt of force coil command to gate transition of the output mosfet. Effective time will vary with output load.

Output Over-Temperature Protection: Outputs will turn-off if the junction temperature of the output switch exceeds 165°C. Cycling the output off/on will restart the output.

Output Over-Current Protection: Outputs will turn-off if the drain current reaches 5A. Cycling the output off/on will restart the output.

### Enclosure/Physical Specifications

See Drawing Enclosure Dimensions (4501-857). Units are packaged in a general purpose plastic enclosure that is DIN rail mountable for flexible, high density (approximately 1" wide per unit) mounting.

Dimensions: Width = 1.05 inches, Height = 4.68 inches, Depth = 4.35 inches (see Drawing Enclosure Dimensions (4501-857)).

DIN Rail Mounting (-xx0x): DIN rail mount, Type EN50022; “T” rail (35mm)

Connectors: Removable plug-in type terminal blocks; Current/Voltage Ratings: 15A/300V; Wire Range: AWG #12-24, stranded or solid copper; separate terminal blocks are provided for each pair of inputs, power/network, and digital outputs. For supply connections, use No. 14 AWG copper wires rated for at least 75°C.

Case Material: Self-extinguishing NYLON type 6.6 polyamide thermoplastic UL94 V-2, color beige; general purpose NEMA Type 1 enclosure.

Printed Circuit Boards: Military grade FR-4 epoxy glass.

Shipping Weight: 1 pound (0.45 Kg) packed.

### Approvals (-xxx0)

0: Agency Approvals Pending - CE, UL Listed, and cUL Listed. UL3121 First Edition, CSA C22.2 No. 1010.1-92, Low Voltage Directive (72/23/EEC), EMC (89/336/EEC) Directives.

Product approval is limited to general safety requirements of the above standards.

**Warning:** This product is NOT approved for hazardous location applications.

### Environmental Specifications

Operating Temperature: -25°C to +70°C (-13°F to +158°F).

Storage Temperature: -40°C to +85°C (-40°F to +185°F).

Relative Humidity: 5 to 95% non-condensing.

Power Requirements: Non-polarized 10-36V DC SELV (Safety Extra Low Voltage), or 22-26 VAC. See table below for current.

**Caution:** Do not exceed 36VDC peak, to avoid damage to the module.

#### DI-913MB/DI-914MB Supply Current

Supply	DI-913MB/DI-914MB
10V	105mA Typical, 125mA Maximum
12V	85mA Typical, 100mA Maximum
15V	65mA Typical, 80mA Maximum
24V	45mA Typical, 50mA Maximum
36V	35mA Typical, 40mA Maximum
24VAC	85mA Typical, 100mA Maximum

#### Power Supply Effect

Volts: Less than ±0.001% of output span change per volt for rated power supply variations.

60/120 Hz Ripple: Less than 0.01% of output span per volt peak-to-peak of power supply ripple.

**Isolation:** Input, network, and power & digital I/O circuits are isolated from each other for common-mode voltages up to 250VAC, or 354V DC off DC power ground, on a continuous basis (will withstand 1500VAC dielectric strength test for one minute without breakdown). This complies with test requirements of ANSI/ISA-82.01-1988 for the voltage rating specified. Inputs are additionally isolated channel-to-channel for common mode voltage to  $\pm 4V$  DC.

**Installation Category:** Designed to operate in an Installation Category (Overvoltage Category) II environment per IEC 1010-1 (1990).

**Radiated Field Immunity (RFI):** Complies with IEC1000-4-3 Level 3 (10V/M, 80 to 1000MHz AM & 900MHz keyed) and European Norm EN50082-1.

**Electromagnetic Interference Immunity (EMI):** No alarm trips will occur beyond  $\pm 0.25\%$  of input span from setpoint, and no output shifts will occur beyond  $\pm 0.25\%$  of span, while under the influence of EMI from switching solenoids, commutator motors, and drill motors.

**Electrical Fast Transient Immunity (EFT):** Complies with IEC1000-4-4 Level 3 (2KV power; 1KV signal lines) and European Norm EN50082-1.

**Electrostatic Discharge (ESD) Immunity:** Complies with IEC1000-4-2 Level 3 (8KV/4KV air/direct discharge) to the enclosure port and European Norm EN50082-1.

**Surge Immunity:** Complies with IEC1000-4-5 Level 3 (2.0KV) and European Norm EN50082-1.

**Radiated Emissions:** Radiated Emissions: Meets or exceeds European Norm EN50081-1 for class B equipment.

## **Communication Interface Specifications**

These units contain an isolated RS485 communication port for the transmission of data.

**Interface Standard:** RS-485. Communication with this module is made over a 3-wire cable (D, D-bar, and Common).

**Command/Response Protocol:** Standard Modbus RTU protocol implemented as defined under “Modicon Modbus Reference Guide” PI-MBUS-300 Rev J (reference [www.public.modicon.com](http://www.public.modicon.com), search keyword PI-MBUS-300 to obtain technical publication). See 4. Module Configuration for a review of Modbus & commands.

**Baud Rate:** Can be programmed for 2400, 4800, 9600 (Default Mode rate), 14400, 19200, 28800, 38400, 57600, 76800, or 115200 bits per second.

**Duplex:** Half Duplex only.

**Parity:** Odd, Even, or None (Default Mode).

**Stop Bits:** One for Even or Odd parity, two for no parity.

**Response Delay:** The minimum communication turnaround delay that a module will wait before it sends its response to a message from the host. It is applied in addition to the inherent delay already present which varies between models. It can be set from 0-65500 ticks, with 1 tick equivalent to 1.085us. Some signal converters or host/software systems cannot accept an immediate response from the slave without additional delay. Note that you may have to specify an amount of delay that is comparable to the inherent delay already present before an effect can be measured.

**Module Address:** Can be set from 0-247 (01H-F7H). The Default Mode address is 247 (F7H).

**Network Capacity:** The Module has multi-drop capability for up to 31 modules, plus host, without use of an RS485 repeater. If a signal repeater is used for every 31 nodes, up to 247 modules may be networked, plus a host computer.

**Communication Distance:** Up to 4000 feet without a repeater. Distance can be extended with the use of a signal repeater.

**Default Communication Mode Parameters:** In this mode, the module address is set to 247, the baud rate is set to 9600bps, the parity is set to none, and the number of stop bits is set to 2 by pressing the DFT push-button on the front of the module until the yellow Status LED flashes ON/OFF. This is provided as a means to communicate with a module when its internal address, baud rate, parity, and stop bit settings are unknown. Exit the Default Mode by pressing this button until the Status LED is NOT flashing (constant ON or OFF), or by issuing a software or power-on reset. Note that new communication parameters for module address, baud rate, and parity do not take effect outside of Default Mode until a software or power-on reset has occurred.

**Watchdog Timer:** A hardware watchdog timer is built into the microcontroller that causes it to initiate a self reset if the controller ever fails to return from an operation in a timely manner or “locks up.” Additionally, an I/O watchdog timer function is implemented that may be configured for timeout periods up to 65534 seconds (18.2 hours). The I/O watchdog timer will cause the status LED to blink rapidly, set a bit in the Module Status Register, and optionally program the digital outputs to a pre-defined state upon watchdog timeout. The I/O watchdog timer is reinitiated via a read or write to any input/output channel. Clearing a timeout condition will not automatically restore the outputs to their initial state. Outputs have to be driven manually or under alarm control.

**Supported Modbus Commands:** Supported Modbus Commands: The command & response protocol for communicating with this module adheres to the Modbus/RTU standard for the following Modbus Functions (the register reference addresses that the function operates on are also indicated):

Code	Function	Reference
01 (01H)	Read Coil (Output) Status	0xxxx
03 (03H)	Read Holding Registers	4xxxx
04 (04H)	Read Input Registers	3xxxx
05 (05H)	Force Single Coil (Output)	0xxxx
06 (06H)	Preset Single Register	4xxxx
08 (08H)	Reset Slave	Hidden
15 (0FH)	Force Multiple Coils (Outputs)	0xxxx
16 (10H)	Preset Multiple Registers	4xxxx
17 (11H)	Report Slave ID	Hidden

Refer to 4. Module Configuration for detailed information on these functions.

### **Configuration and Controls**

**Module Push Button (See Drawing Enclosure Dimensions (4501-857) For Location):** Default (DFT) - Push to engage or disengage the default communication mode with baud rate set to 9600bps, module address set to 247, and no parity selected. The Status LED will flash ON/OFF when the module is in the default mode. A module will leave the default mode following a software or power-on reset (Status LED will be OFF or constant ON).

LED Indicators: Run (Green) - Constant ON indicates power is applied and unit is operating normally. Flashing ON/OFF indicates unit is performing diagnostics (first two seconds following power-up), or has failed diagnostics (after a few seconds).

Status (Yellow) - Flashing ON/OFF indicates the module is in the Default Communication Mode. A rapidly flashing status LED also indicates an I/O watchdog timeout has occurred. A constant ON indicates an input is outside of the transmitter's calibrated input range (when module is outside of default mode only).

**IMPORTANT:** The out-of-range indication will mask watchdog timeout indication and default mode indication.

Output (Yellow) - One per output. OFF if output switch is OFF, ON if output switch is ON. Can also be used to indicate an alarm condition for the associated input.

## Software Configuration

Units are fully reprogrammable via our user-friendly Windows 95/98<sup>®</sup> or NT<sup>®</sup> DI-900MB Configuration Program. See Drawing Network Connections (4501-805).

The following transmitter attributes are configurable via the DI-900MB Configuration Software. Optionally, any software that supports the Modbus command/response protocol may be used. Use the Preset Single/Multiple Register functions to write configuration data to the appropriate register(s) as required by your application (see Register Map).

### Slave Communication

- Slave - ID: The Report Slave ID command will return the model number, run on/off status, module serial number, and firmware number.
- Slave - Reset: This command is used to trigger a reset of the module and its effect is equivalent to a power-on reset. An alternate method of resetting a module can be accomplished via a write to the Calibration Access & Reset Register (see Memory Map register 40024). This is provided to accomplish reset with modbus software that does not support the Reset Slave command.
- Slave - Address: Select valid slave addresses in the range of 1-247 (01H-F7H). Address 247 is the default mode slave address.
- Slave - Baud Rate: Select 2400, 4800, 9600 (default), 14400, 19200, 28800, 38400, 57600, 76800, or 115200 bits per second.
- Slave - Parity: Select Even, Odd, or No Parity (See Parity Checking) error checking. Odd or even parity bit is followed by 1 stop bit. If no parity is selected, 2 stop bits are used.
- Slave - Response Delay: Can be set from 0-65500 ticks (1 tick = 1.085us) and refers to the additional delay a module will wait before it sends its response to a message from the host. Some signal converters or host/software systems cannot accept a response to a message immediately after sending the message without additional delay.
- Slave - Status: The Module Status Register can be used to determine alarm status, I/O watchdog timeout, A/D status, and the internal flash memory checksum error status.



**Slave - Watchdog:** A watchdog timer may be applied to the I/O channels of this module. Use the Watchdog Time Register to select a timeout period from 1 to 65534 seconds (18.2 hours). A time of 65535 (FFFFH) or 0 (0000H) will disable the I/O watchdog timer. Use the Timeout State Register to define the states that the outputs are to be programmed to upon I/O timeout. The four lower order bits of this register value define the timeout states of each of the four output channels. Watchdog timeout state control takes precedence over alarm and direct control of the output channels. Writing 65535 (FFFFH) to the Timeout States Register will leave the port outputs unchanged upon timeout. A watchdog fault indication flag (bit 0 of the Module Status register) will be set if any of the module output channels have not been written to over the specified time period, or if any of the I/O channels have not been read over the specified time period. In addition, the module status LED will blink rapidly if a watchdog timeout occurs.

### Analog Input

**Input - Range/Type:** Select voltage or current ranges according to model number. Refer to Analog Input Specifications for signal ranges. Note that this model uses percent-of-span units.

**IMPORTANT:** Multiple inputs of module must be configured for the same range/type (same gain).

**Input Calibration:** The configuration software can be used to calibrate the input conditioning circuit of this module (see 6. Module Software Configuration), or by using the Preset Register Functions to write the appropriate data to the calibration registers (see Register Map).

### Digital Outputs

**Output - State:** The coil registers (0x references) may be read via the Read Coil (01) command to determine the current state of the outputs. The current output state is also indicated by a yellow status LED at the front of the module which lights when the corresponding output is sinking current. The Force Single Coil (05) and Force Multiple Coil (15) commands may be used to directly control the output state via the coil registers. The outputs may also be set under alarm control at the corresponding input channel, or via watchdog timeout control.

**IMPORTANT:** Alarm limits take precedence over direct control and must be disabled if direct control is desired. Watchdog timeout control has highest priority (if enabled).

### Channel Alarm Configuration

**Channel - Alarm Output State & Output Enable:** Use the Alarm Output State and Alarm Output Enable Register to enable the corresponding discrete output as an alarm output and to select failsafe or non-failsafe alarm output activation. A failsafe alarm output will turn OFF in alarm (the same state as the power-down state). A non-failsafe alarm output will turn ON in alarm. Alarm limit checking is always active for the module, but assignment of an alarm output is optional via this control.

**Channel - High Limit Value:** Use the channel High Limit Value Register to write a high limit value. Limit values use scaled percent-of-span units ( $\pm 20000$  represents  $\pm 100\%$ ) and must be within the full input range (see Analog Input Specifications).

The corresponding digital output will transfer to the alarm state when the high limit value is exceeded and remains at that state until the input signal has retreated below the limit, plus any deadband.

**Channel - Low Limit Value:** Use the channel Low Limit Value Register to write a low limit value. Limit values use scaled percent-of-span units ( $\pm 20000$  represents  $\pm 100\%$ ) and must be within the full input range (see Analog Input Specifications). The corresponding digital output transfer to the alarm state when the low limit value is exceeded and remains at that state until the input signal has retreated above the low limit, plus any deadband.

**Channel - Deadband Value:** Use the channel Deadband Value Register to assign deadband to limit checking. Deadband values use scaled percent-of-span units ( $\pm 20000$  represents  $\pm 100\%$ ) and must be within the full input range (see Analog Input Specifications). Deadband determines the amount the input signal has to return into the “normal” operating range before the output will turn OFF. Deadband is normally used to eliminate false trips or alarm “chatter” caused by fluctuations in the input near the alarm point.

**IMPORTANT:** Noise and/or jitter on the input signal has the effect of reducing (narrowing) an instrument’s deadband and may produce output chatter. Another long term effect of output chatter is a reduction in the life of any mechanical relay controlled via the output. To reduce this undesired effect, increase the deadband setting.

**Visual Alarm Output Indication:** The yellow output LED can provide visual status indication of when the corresponding channel is in alarm. This LED is turned ON when the output is switched ON. This LED is also turned ON when the output is switched ON independent of the alarm. Note that alarm control (when enabled) takes precedence over direct control of the output states and watchdog timeout control has the highest precedence.

**Software Alarm Indication:** The Module Status Register can be used to determine if any of the module’s inputs are in alarm. The Channel Status Register can be used determine when a specific input is in alarm.

### ***Other Modbus Configuration Software Capabilities***

In addition to configuring all features of the module described above, the Modbus Configuration Software includes additional capabilities for testing and control of this module as follows:

1. Monitors the input signal values and the discrete output signal states. It also allows polling to be turned on or off.
2. Allows a configuration to be uploaded or downloaded to/from the module via the RS485 interface.
3. Provides controls to separately calibrate each input and to restore the original factory input calibration in case of error.
4. Provides controls to reset a module.
5. Reads the contents of the Module Status Register.
6. Allows optional user documentation to be saved to a module file. Documentation fields are provided for tag number, comment, configured by, location, and identification information. This information can also be printed via this software.
7. Allows a module’s complete configuration to be printed in an easy to read, one or two page format, including user documentation.

# 3. Getting Started

## Unpacking and Inspection

Upon receipt of this product, inspect the shipping carton for evidence of mishandling during transit. If the shipping carton is badly damaged or water stained, request that the carrier's agent be present when the carton is opened. If the carrier's agent is absent when the carton is opened and the contents of the carton are damaged, keep the carton and packing material for the agent's inspection. For repairs to a product damaged in shipment, refer to the Warranty and Service Policy to obtain return instructions. It is suggested that salvageable shipping cartons and packing material be saved for future use in the event the product must be shipped.

This module is physically protected with packing material and electrically protected with an anti-static bag during shipment. However, it is recommended that the module be visually inspected for evidence of mishandling prior to applying power.

This circuit utilizes static sensitive components and should only be handled at a static-safe workstation.



## Module Installation

This transmitter module is packaged in a general purpose plastic enclosure. Use an auxiliary enclosure to protect the unit in unfavorable environments or vulnerable locations, or to maintain conformance to applicable safety standards. Stay within the specified operating temperature range. As shipped from the factory, the unit is calibrated for all valid input ranges and has the default configuration shown in the table below.

**WARNING:** Applicable IEC Safety Standards may require that this device be mounted within an approved metal enclosure or sub-system, particularly for applications with exposure to voltages greater than or equal to 75VDC or 50VAC.

**DI-913MB/DI-914MB Default Factory Configuration**

Parameter	Configuration/Calibration
Module Address	247
Baud Rate	9600bps
Parity	None
Stop Bits	2 (When Parity=None)
Response Delay	0 (No Delay)
Watchdog Time	0 (Disabled)
Output Timeout States	All ON (Timer Disabled)
Input Range (DI-913MB)	0-20mA DC
Input Range (DI-914MB)	±10V DC
Limit Configuration (Each Input)	Alarm Outputs Disabled
High Limit Value (Each Input)	100% (High Endpoint)
Low Limit Value (Each Input)	-100% (Low Endpoint)
Deadband (Each Input)	1%

**Note:** Do not confuse the Default Factory Configuration noted above with the Default Communication Mode, which refers to the fixed baud rate, module address, parity, and stop bit settings achieved by pushing the Default Mode button until the status LED flashes ON/OFF. The Default Communication Mode will temporarily over-ride any factory configuration of baud rate, module address, parity, and stop bits with settings of 9600bps, 247, None, and 2, respectively. It is provided as a convenient means of achieving communication with a module when these parameters are unknown.

Your application will typically differ from the default factory configuration and will require that the transmitter be reconfigured to suit your needs. This can be easily accomplished with the user-friendly Windows 95/98<sup>®</sup> or NT<sup>®</sup> DI-900MB Configuration Program. Configuration is normally done prior to field installation. Refer to 6. Module Software Configuration for detailed instructions.

### **Default Mode Switch**

A push-button default mode switch and status LED are provided at the front of the module as a convenient way of communicating with the module when its baud rate and address settings are unknown. Push and hold this button until the Status LED flashes ON/OFF to indicate the module is in the Default Communication Mode with a fixed module address of 247, baud rate of 9600bps, no parity, and 2 stop bits. It is most convenient to configure a module in this mode, then leave the default mode by pressing this button again until the Status LED stops flashing (constant ON or OFF), or by resetting the module. The Default Mode is disabled following a software or power-on reset. New communication parameters (for baud rate, address, and parity) will take effect following a reset of the module after leaving the Default Mode.

**IMPORTANT:** The default mode is indicated via a flashing status LED. However, if an input is left open or floating, the status LED may turn ON to indicate a signal over-range condition and this will mask default mode indication. **DO NOT LEAVE UNUSED CHANNELS OPEN OR FLOATING.** It is recommended that you short unused input channels.

### **Mounting**

Refer to Drawing Enclosure Dimensions (4501-857) for mounting and clearance dimensions.

**DIN Rail Mounting:** This module can be mounted on “T” type DIN rails. Use suitable fastening hardware to secure the DIN rail to the mounting surface. Units may be mounted side-by-side on 1-inch centers for limited space applications.

**“T” Rail (35mm), Type EN50022:** To attach a module to this style of DIN rail, angle the top of the unit towards the rail and locate the top groove of the adapter over the upper lip of the rail. Firmly push the unit towards the rail until it snaps solidly into place. To remove a module, first separate the input terminal block(s) from the bottom side of the module to create a clearance to the DIN mounting area. Next, insert a screwdriver into the lower arm of the DIN rail connector and use it as a lever to force the connector down until the unit disengages from the rail.

### **Electrical Connections**

Digital output, network, power, and input terminals can accommodate wire from 12-24 AWG, stranded or solid copper. Strip back wire insulation 1/4-inch on each lead before installing into the terminal block. Analog input wiring should be shielded twisted-pair. Since common mode voltages can exist on signal wiring, adequate wire insulation should be used and proper wiring practices followed. It is recommended that transmitter network, digital I/O, and power wiring be separated from the input signal wiring for safety, as well as for low noise pickup. Note that input, power, network, and digital I/O terminal blocks are a plug-in type and can be easily removed to facilitate module removal or replacement, without removing individual wires. Be sure to remove power before unplugging the terminals to uninstall the module, or before attempting service. All connections must be made with power removed.

**CAUTION:** Risk of Electric Shock - More than one disconnect switch may be required to de-energize the equipment before servicing.

1. **Power:** Refer to Electrical Connections (4501-855). Variations in power supply voltage within rated limits has negligible effect on module accuracy. For supply connections, use No. 14 AWG wires rated for at least 75°C. The power terminals are diode bridge-coupled and not polarized. The unit is powered from 10-36VDC, or 24VAC only.
2. **Inputs:** Connect inputs per Electrical Connections Drawing 4501-855. Observe proper polarity when making input connections (see label for input type). Unused inputs should not be left open or floating and should be

shorted. For increased noise immunity, the voltage inputs are isolated channel-to-channel for common mode voltages up to  $\pm 4V$ . Be careful that your application does not inadvertently exceed these limits, or damage to the unit may result.

**IMPORTANT:** Noise and/or jitter on the input signal has the effect of reducing (narrowing) the instrument's deadband and may produce switch chatter when using the alarm output. The long term effect of this will reduce the life of mechanical relays if connected to these outputs. To reduce this undesired effect, you should increase the effective deadband.

3. **Outputs (Coils):** All outputs are the open-drains of n-channel mosfets whose source terminals share return (RTN). Externally wired output pullups may be required. All outputs include transient voltage suppressers and integrated snubbers, but may require additional protection when switching inductive loads (see below). Refer to 2. Specifications for output specifications and see the module side label for terminal designations. Note that these outputs are for current-sinking (low-side switching) applications only. Observe proper polarity when making connections. The output circuit as a group is electrically isolated from the input, power, and network circuits. If necessary, an interposing relay can be used to switch higher currents as illustrated in the Interposing Relay Connection Drawing 4501-856.

**Note:** Digital outputs go to their OFF state following a software or power-on reset of the module. Outputs may be optionally sent to user-defined states following a watchdog timeout.

**IMPORTANT - Protection With Inductive Loads:** The output mosfets have integrated shunt diode clamps connected from drain to source to help protect the output switch from damaging reverse emf voltages that exist when controlling inductive loads. You may need to add external protection local to the inductive load for added protection and to prevent this emf from being distributed across the connection media. For DC inductive loads, place a diode across the load (1N4006 or equivalent) with cathode to (+) and anode to (-).

4. **Network Connections:** Wire network as shown in Drawing 4501-805. Network common (COM) should connect to earth ground at one point.
5. **Grounding:** See Drawing Electrical Connections (4501-855). The module housing is plastic and does not require an earth ground connection..

<p><b>WARNING:</b> For compliance to applicable safety and performance standards, the use of shielded cable is recommended as shown in Drawing 4501-855. Further, the application of earth ground must be in place as shown in Drawing 4501-855. Failure to adhere to sound wiring and grounding practices may compromise safety &amp; performance.</p>
---

## Software Installation

The 900MB Configuration Software is used to configure Series DI-900MB modules and is installed as follows:

1. Insert the DI-900MB Resource CD into your CD-ROM drive.

**IMPORTANT:** Before continuing with installation, be sure to exit any other Windows programs that may be running.

2. The Window's AutoRun feature should start the CD and the installation software will run.
3. Select the option "Install DI-900MB Configuration Software" and click on OK.
4. The Welcome Dialog Box appears. Click on Next to continue with the installation or Cancel to abort.
5. Fill out your user information in the appropriate text boxes and click on Next.

6. The Choose Destination dialog box allows you to specify the program files' destination directory. To keep the default (C:\Program Files\Series900MB) click on Next, to change the destination click on the Browse button, select a destination, then click on Next.
7. The Select Program Folder allows you to designate the program folder. To keep the default (Series900MB), click on Next, to choose a different folder, make a selection from the list then click on Next.
8. The Start Copying Files dialog box shows the current settings and allows you to change them by using the Back button. To change settings, click on the Back button until you reach the setting you would like to change, change that setting, and click on the Next button until you get back to the Start Copying Files dialog box. To keep the current settings and install the software, click on the Next button.
9. Setup is complete. Click Finish to exit the DATAQ installation program and return to Windows.
10. To run the configuration software, go to the Start Menu and click on Programs > Series900MB > Series900MB Configuration (this is the default - if you did not keep the default settings choose the program folder and directory you had specified during installation).

# 4. Module Configuration

This module needs to be configured for your application. Configuration is easily accomplished using the Windows 95/98® or NT® Modbus Configuration Software and an RS232-to-RS485 signal converter. It is not required to use the DATAQ software to communicate with the Series DI-900MB, as any software capable of sending Modbus protocol commands over an RS485 network can be used. However, the Configuration Software does provide an easy to use Windows format for communicating with the module that does not require advanced familiarity with the Modbus protocol.

## Register Map

Modbus registers are organized into the following reference types identified by the leading number of the reference address:

Reference	Description
0xxxx	Read/Write Discrete Outputs or Coils. A 0x reference address is used to drive output data to a digital output channel.
1xxxx	Read Discrete Inputs. The ON/OFF status of a 1x reference is controlled by the corresponding digital input channel.
3xxxx	Read Input Registers. A 3x reference register contains a 16-bit number received from an external source-e.g. an analog signal.
4xxxx	Read/Write Output or Holding Registers. A 4x register is used to store 16-bits of numerical data (binary or decimal), or to send the data from the CPU to an output channel.

### Notes:

1. The “x” following the leading character represents a four-digit address location in user data memory. The leading character is generally implied by the function code and omitted from the address specifier for a given function. The leading character also identifies the I/O data type.
2. The ON/OFF state of discrete inputs and outputs is represented by a 1 or 0 value assigned to an individual bit in a 16-bit data word. With respect to mapping, the LSB of the word maps to the lowest numbered channel of a group and channel numbers increase sequentially as you move towards the MSB. Unused bits are set to zero.

Modbus functions operate on register map registers to configure and control modules. The following table outlines the register map for Model DI-913MB and DI-914MB network I/O modules. You will find it helpful to refer to this map as you review the Modbus function descriptions later.

Ref	Addr.	Description	Data Type/Format
<b>Coil Registers (0x References, Read/Write)</b>			
00001 Thru 00004	0-3(0000- 0003)	Four Discrete Outputs 0-3	Discrete Output Value. Addresses a specific bit of a 16-bit word that controls/ monitors the ON/OFF status for the output. A set bit (1) means the corresponding output is ON. A clear bit (0) means the corresponding output is OFF. The bit position corresponds to the output channel number (i.e. output 0 uses bit 0 of the 16-bit word at address 0, output 1 uses bit 1 of the 16-bit word at address 1, etc.) Unused bits of a word are set to 0. Bits 15-4: Not Used. Additionally, unused bits in range 3-0 are set to 0. <b>IMPORTANT:</b> Disable the corresponding limits if you wish to control the state of a discrete output directly via these registers as limit alarm functionality takes precedence.

Ref	Addr.	Description	Data Type/Format
<p><b>Note:</b> This signal corresponds to the gate signal of the n-channel output mosfet. Thus, a read of this register may not reflect the actual output level at the drain of the mosfet if the open-drain is not pulled up or is left floating. Excitation must be provided in order to operate the outputs. After reset, these registers read 0 (outputs OFF) and these registers are not maintained in EEPROM.</p>			
<b>Input Registers (3x References, Read-Only)</b>			
30001	0 (0000)	Module Status	Bit 15: Flash Checksum; 1 = Error Flag; 0 = No Flash Error Bit 14: A/D Error Flag; 1 = A/D Error; 0 = No A/D Error Bit 13: Default Mode Flag; 1 = Default Mode Indication; 0 = Not In Default Mode Bits 12-4: Zero Bit 3: I/O Watchdog Fault; 1 = Watchdog Timeout; 0 = No Time-out Bit 2: Limit Detect Flag; 1 = Global Limit Exceeded; 0 = No Limit Exceeded Bits 1-0: Zero
30002	1 (0001)	Current Input Configuration Register <b>DI-913MB Models</b>	Bits 15-4: Zero Bits 3,2,1,0: DI-913MB Input Range Only 0000 = 0 = 0-20mA DC 0001 = 1 = 4-20mA DC 0010 = 2 = 0-11.17mA DC 0011 = 3 = 0-1mA DC xxxx = 3-15 = Reserved
30002	1 (0001)	Current Input Configuration Register <b>DI-914MB Models</b>	Bits 15-4: Zero Bits 3,2,1,0: DI-914MB Input Range Only 0000 = 0 = ±10V DC 0001 = 1 = ±5V DC 0010 = 2 = ±2.5V DC 0011 = 3 = ±1.25VDC 0100 = 4 = ±625mV DC 0101 = 5 = ±313mV DC 0110 = 6 = ±156mV DC 0111 = 7 = ±78mV DC 1xxx = 8-15 = Reserved
30003	2 (0002)	CH 0 Input Value	Percentage (%) <sup>5</sup>
30004	3(0003)	CH 0 Status Value	Bits 15-4: Zero Bit 3: High Limit Flag 1 = High Limit Exceeded; 0 = Below High Limit Bit 2: Low Limit Flag 1 = Low Limit Exceeded; 0 = Above Low Limit Bits 1,0: Under/Over Range 00 = In Range; 01 = Overrange; 10 = Under Range; 11 = Not Defined
30005	4 (0004)	CH 1 Input Value	Percentage (%) <sup>5</sup>
30006	5 (0005)	CH 1 Status Value	Format Is Same As CH 0
30007	6 (0006)	CH 2 Input Value	Percentage (%) <sup>5</sup>
30008	7 (0007)	CH 2 Status Value	Format Is Same As CH 0
30009	8 (0008)	CH 3 Input Value	Percentage (%) <sup>5</sup>
30010	9 (0009)	CH 3 Status Value	Format Is Same As CH 0
30011	10 (000A)	CH0 Raw Count	Raw A/D Count Value <sup>3</sup>
30012	11 (000B)	CH1 Raw Count	Raw A/D Count Value <sup>3</sup>
30013	12 (000C)	CH2 Raw Count	Raw A/D Count Value <sup>3</sup>



Ref	Addr.	Description	Data Type/Format
30014	13 (000D)	CH3 Raw Count	Raw A/D Count Value <sup>3</sup>
<b>Holding Registers (4x References, Read/Write)</b>			
<b>Note:</b> Changes to Holding Registers take effect following the next software or power-on reset of the module, except for the Reset Register.			
40001	0 (0000)	Slave Address Default=247	1-247
40002	1 (0001)	Baud Rate Default = 2, 9600bps	0 = 2400bps 1 = 4800bps 2 = 9600bps (Default) 3 = 14400bps 4 = 19200bps 5 = 28800bps 6 = 38400bps 7 = 57600bps 8 = 76800bps 9 = 115200bps
40003	2 (0002)	Parity Default=0, None	0 = None (2 stop bits) 1 = Odd Parity Checking (1 stop bit) 2 = Even Parity Checking (1 stop bit)
40004	3 (0003)	Port 0 (CH0-3) Watchdog Time Default=0, Disabled	Can be set from 1 to 65534 seconds. Set to 65535 (FFFFH) or 0 (0000H) to disable the watchdog timer (0000H/disabled is the default value).
40005	4 (0004)	Output Channel Time-out States  Default=65535, Disabled	The four lower order bits of this 16-bit register value define the state the output channels will be programmed to following a watchdog timeout. Bit 0 corresponds to channel 0, bit 1 to channel 1, bit 2 to channel 2, and bit 3 to channel 4. Write 65535 (FFFFH) to this register to leave the outputs unchanged following a timeout (this is also the default value). Note that watchdog timeout control takes precedence over alarm and direct control of the digital output.
40006	5 (0005)	Response Delay Time (Turnaround Delay) Default=0, No Delay	Can be set from 0 to 65500 ticks (1 tick = 1.085us). This is the additional delay the module will wait before responding to a host message. The default value is 0 (no delay). Increase this value if you are having communication problems or you encounter a high degree of error messages.
40007	6 (0006)	<b>DI-913MB</b> Input Configuration (applies to all four inputs) Default=0, 0-20mA	Bits 15-4: Zero Bits 3,2,1,0: DI-913MB Input Range Only 0000 = 0 = 0-20mA DC 0001 = 1 = 4-20mA DC 0010 = 2 = 0-11.17mA DC 0011 = 3 = 0-1mA DC xxxx = 4-15 = Reserved

Ref	Addr.	Description	Data Type/Format
40007	6 (0006)	<b>DI-914MB Input</b> Configuration (applies to all four inputs) Default=0, ±10V	Bits 15-4: Zero Bits 3,2,1,0: DI-914MB Input Range Only 0000 = 0 = ±10V DC 0001 = 1 = ±5V DC 0010 = 2 = ±2.5V DC 0011 = 3 = ±1.25VDC 0100 = 4 = ±625mV DC 0101 = 5 = ±313mV DC 0110 = 6 = ±156mV DC 0111 = 7 = ±78mV DC 1xxx = 8-15 = Reserved
40008	7 (0007)	CH0 High Limit Default=100%	Percentage (%) <sup>5</sup>
40009	8 (0008)	CH0 Low Limit Default = -100% (DI-914MB) 0% (DI-913MB)	Percentage (%) <sup>5</sup>
40010	9 (0009)	CH0 Deadband Default= 1%	Percentage (%) <sup>5</sup>
40011	10 (000A)	CH0 Alarm Output State & Alarm Output Enable Default=0, Dis- abled	Bits 15-3: Zero Bit 2: Alarm Out State; 0 = Failsafe (OFF); 1 = Non-Failsafe (ON) Bit 1: High Limit; 1 = Hi Output Enabled; 0 = Hi Output Disabled Bit 0: Low Limit; 1 = Lo Output Enabled; 0 = Lo Output Dis- abled
40012	11 (000B)	CH1 High Limit Default=100%	Percentage (%) <sup>5</sup>
40013	12 (000C)	CH1 Low Limit Default = -100% (DI-914MB) 0% (DI-913MB)	Percentage (%) <sup>5</sup>
40014	13 (000D)	CH1 Deadband Default= 1%	Percentage (%) <sup>5</sup>
40015	14 (000E)	CH1 Alarm Output State & Alarm Output Enable Default=0, Disabled	Bits 15-3: Zero Bit 2: Alarm Out State; 0 = Failsafe (OFF); 1 = Non-Failsafe (ON) Bit 1: High Limit; 1 = Hi Output Enabled; 0 = Hi Output Disabled Bit 0: Low Limit; 1 = Lo Output Enabled; 0 = Lo Output Dis- abled
40016	15 (000F)	CH2 High Limit Default= 100%	Percentage (%) <sup>5</sup>
40017	16 (0010)	CH2 Low Limit Default = -100% (DI-914MB) 0% (DI-913MB)	Percentage (%) <sup>5</sup>
40018	17 (0011)	CH2 Deadband Default= 1%	Percentage (%) <sup>5</sup>
40019	18 (0012)	CH2 Alarm Output State & Alarm Output Enable Default=0 Disabled	Bits 15-3: Zero Bit 2: Alarm Out State; 0 = Failsafe (OFF); 1 = Non-Failsafe (ON) Bit 1: High Limit; 1 = Hi Output Enabled; 0 = Hi Output Disabled Bit 0: Low Limit; 1 = Lo Output Enabled; 0 = Lo Output Dis- abled

Ref	Addr.	Description	Data Type/Format
40020	19(0013)	CH3 High Limit Default=20000, 100%	Percentage (%) <sup>5</sup>
40021	20 (0014)	CH3 Low Limit Default = -100% (DI-914MB) 0% (DI-913MB)	Percentage (%) <sup>5</sup>
40022	21 (0015)	CH3 Deadband Default= 1%	Percentage (%) <sup>5</sup>
40023	22 (0016)	CH3 Alarm Output State & Alarm Output EnableDefault=0, Dis- abled	Bits 15-3: Zero Bit 2: Alarm Out State; 0 = Failsafe (OFF); 1 = Non-Failsafe (ON) Bit 1: High Limit; 1 = Hi Output Enabled; 0 = Hi Output Disabled Bit 0: Low Limit; 1 = Lo Output Enabled; 0 = Lo Output Dis- abled
40024	23 (0017)	Calibration Access  And  Alternate Method of Module Reset	Writing 24106 (5E2AH) here immediately removes write protec- tion from the calibration registers that follow. All other values apply write protection to the calibration registers (except 41429). Writing 41429 (A1D5H) to this register will cause an immediate module reset. This is provided as an alternate method of Reset for software that does not support the Reset Slave (08) command. After a reset, this register reads 0 (write protection enabled and no reset). This register is not maintained in EEPROM.
<b>IMPORTANT:</b> Access to calibration registers 40025 through 40104 is not normally required and writes to these registers should be avoided to prevent module miscalibration. Shaded calibration registers apply to the Model DI-914MB and unshaded calibration registers apply to Model DI-913MB.			
40025	24 (0018)	CH0 0-20mA Cal HI Value (DI-913MB)	Raw A/D Count Value <sup>3</sup>
40025	24 (0018)	CH0 ±10V Cal HI Value (DI-914MB)	Raw A/D Count Value <sup>3</sup>
40026	25 (0019)	CH0 0-20mA Cal LO Value (DI-913MB)	Raw A/D Count Value <sup>3</sup>
40026	25 (0019)	CH0 ±10V Cal LO Value (DI-914MB)	Raw A/D Count Value <sup>3</sup>
40027	26 (001A)	CH0 4-20mA Cal HI Value (DI-913MB)	Raw A/D Count Value <sup>3</sup>
40027	26 (001A)	CH0 ±5V Cal HI Value (DI-914MB)	Raw A/D Count Value <sup>3</sup>
40028	27 (001B)	CH0 4-20mA Cal LO Value (DI-913MB)	Raw A/D Count Value <sup>3</sup>
40028	27 (001B)	CH0 ±5V Cal LO Value (DI-914MB)	Raw A/D Count Value <sup>3</sup>
40029	28 (001C)	CH00-11.17mA Cal HI Value (DI-913MB)	Raw A/D Count Value <sup>3</sup>
40029	28 (001C)	CH0 ±2.5V Cal HI Value (DI-914MB)	Raw A/D Count Value <sup>3</sup>
40030	29 (001D)	CH00-11.17mA Cal LO Value(DI-913MB)	Raw A/D Count Value <sup>3</sup>
40030	29 (001D)	CH0 ±2.5V Cal LO Value (DI-914MB)	Raw A/D Count Value <sup>3</sup>
40031	30 (001E)	CH00-1mA Cal HI Value (DI-913MB)	Raw A/D Count Value <sup>3</sup>
40031	30 (001E)	CH0 ±1.25V Cal HI Value (DI-914MB)	Raw A/D Count Value <sup>3</sup>

Ref	Addr.	Description	Data Type/Format
40032	31 (001F)	CH00-1mA Cal LO Value(DI-913MB)	Raw A/D Count Value <sup>3</sup>
40032	31 (001F)	CH0 ±1.25V Cal LO Value (DI-914MB)	Raw A/D Count Value <sup>3</sup>
40033	32 (0020)	CH0 ±625mV Cal HI Value	Raw A/D Count Value <sup>3</sup>
40034	33 (0021)	CH0 ±625mV Cal LO Value	Raw A/D Count Value <sup>3</sup>
40035	34 (0022)	CH0 ±313mV Cal HI Value	Raw A/D Count Value <sup>3</sup>
40036	35 (0023)	CH0 ±313mV Cal LO Value	Raw A/D Count Value <sup>3</sup>
40037	36 (0024)	CH0 ±156mV Cal HI Value	Raw A/D Count Value <sup>3</sup>
40038	37 (0025)	CH0 ±156mV Cal LO Value	Raw A/D Count Value <sup>3</sup>
40039	38 (0026)	CH0 ±78mV Cal HI Value	Raw A/D Count Value <sup>3</sup>
40040	39 (0027)	CH0 ±78mV Cal LO Value	Raw A/D Count Value <sup>3</sup>
40041	40 (0028)	CHI 0-20mA Cal HI Value (DI-913MB)	Raw A/D Count Value <sup>3</sup>
40041	40 (0028)	CHI ±10V Cal HI Value (DI-914MB)	Raw A/D Count Value
40042	41 (0029)	CHI 0-20mA Cal LO Value (DI-913MB)	Raw A/D Count Value <sup>3</sup>
40042	41 (0029)	CHI ±10V Cal LO Value(DI-914MB))	Raw A/D Count Value <sup>3</sup>
40043	42 (002A)	CHI 4-20mA Cal HI Value (DI-913MB)	Raw A/D Count Value <sup>3</sup>
40043	42 (002A)	CHI ±5V Cal HI Value(DI-914MB)	Raw A/D Count Value <sup>3</sup>
40044	43 (002B)	CHI 4-20mA Cal LO Value (DI-913MB)	Raw A/D Count Value <sup>3</sup>
40044	43 (002B)	CHI ±5V Cal LO Value (DI-914MB)	Raw A/D Count Value <sup>3</sup>
40045	44 (002C)	CHI0-11.17mA Cal HI Value (DI-913MB)	Raw A/D Count Value <sup>3</sup>
40045	44 (002C)	CHI ±2.5V Cal HI Value (DI-914MB)	Raw A/D Count Value <sup>3</sup>
40046	45 (002D)	CHI0-11.17mA Cal LO Value (DI-913MB)	Raw A/D Count Value <sup>3</sup>
40046	45 (002D)	CHI ±2.5V Cal LO Value (DI-914MB)	Raw A/D Count Value <sup>3</sup>
40047	46 (002E)	CHI0-1mA Cal HI Value (DI-913MB)	Raw A/D Count Value <sup>3</sup>
40047	46 (002E)	CHI ±1.25V Cal HI Value (DI-914MB)	Raw A/D Count Value <sup>3</sup>
40048	47 (002F)	CHI0-1mA Cal LO Value (DI-913MB)	Raw A/D Count Value <sup>3</sup>
40048	47 (002F)	CHI ±1.25V Cal LO Value (DI-914MB)	Raw A/D Count Value <sup>3</sup>

Ref	Addr.	Description	Data Type/Format
40049	48 (0030)	CH1 $\pm 625\text{mV}$ Cal HI Value	Raw A/D Count Value <sup>3</sup>
40050	49 (0031)	CH1 $\pm 625\text{mV}$ Cal LO Value	Raw A/D Count Value <sup>3</sup>
40051	50 (0032)	CH1 $\pm 313\text{mV}$ Cal HI Value	Raw A/D Count Value <sup>3</sup>
40052	51 (0033)	CH1 $\pm 313\text{mV}$ Cal LO Value	Raw A/D Count Value <sup>3</sup>
40053	52 (0034)	CH1 $\pm 156\text{mV}$ Cal HI Value	Raw A/D Count Value <sup>3</sup>
40054	53 (0035)	CH1 $\pm 156\text{mV}$ Cal LO Value	Raw A/D Count Value <sup>3</sup>
40055	54 (0036)	CH1 $\pm 78\text{mV}$ Cal HI Value	Raw A/D Count Value <sup>3</sup>
40056	55 (0037)	CH1 $\pm 78\text{mV}$ Cal LO Value	Raw A/D Count Value <sup>3</sup>
40057	56 (0038)	CH2 0-20mA Cal HI Value (DI-913MB)	Raw A/D Count Value <sup>3</sup>
40057	56 (0038)	CH2 $\pm 10\text{V}$ Cal HI Value (DI-914MB)	Raw A/D Count Value <sup>3</sup>
40058	57 (0039)	CH2 0-20mA Cal LO Value (DI-913MB)	Raw A/D Count Value <sup>3</sup>
40058	57 (0039)	CH2 $\pm 10\text{V}$ Cal LO Value (DI-914MB)	Raw A/D Count Value <sup>3</sup>
40059	58(003A)	CH2 4-20mA Cal HI Value (DI-913MB)	Raw A/D Count Value <sup>3</sup>
40059	58 (003A)	CH2 $\pm 5\text{V}$ Cal HI Value (DI-914MB)	Raw A/D Count Value <sup>3</sup>
40060	59 (003B)	CH2 4-20mA Cal LO Value (DI-913MB)	Raw A/D Count Value <sup>3</sup>
40060	59 (003B)	CH2 $\pm 5\text{V}$ Cal LO Value (DI-914MB)	Raw A/D Count Value <sup>3</sup>
40061	60 (003C)	CH20-11.17mA Cal HI Value (DI-913MB)	Raw A/D Count Value <sup>3</sup>
40061	60 (003C)	CH2 $\pm 2.5\text{V}$ Cal HI Value (DI-914MB)	Raw A/D Count Value <sup>3</sup>
40062	61 (003D)	CH2 0-11.17mA Cal LO Value (DI-913MB)	Raw A/D Count Value <sup>3</sup>
40062	61 (003D)	CH2 $\pm 2.5\text{V}$ Cal LO Value (DI-914MB)	Raw A/D Count Value <sup>3</sup>
40063	62 (003E)	CH20-1mA Cal HI Value(DI-913MB)	Raw A/D Count Value <sup>3</sup>
40063	62 (003E)	CH2 $\pm 1.25\text{V}$ Cal HI Value (DI-914MB)	Raw A/D Count Value <sup>3</sup>
40064	63 (003F)	CH20-1mA Cal LO Value (DI-913MB)	Raw A/D Count Value <sup>3</sup>
40064	63 (003F)	CH2 $\pm 1.25\text{V}$ Cal LO Value (DI-914MB)	Raw A/D Count Value <sup>3</sup>
40065	64 (0040)	CH2 $\pm 625\text{mV}$ Cal HI Value	Raw A/D Count Value <sup>3</sup>
40066	65 (0041)	CH2 $\pm 625\text{mV}$ Cal LO Value	Raw A/D Count Value <sup>3</sup>

Ref	Addr.	Description	Data Type/Format
40067	66 (0042)	CH2 $\pm 313\text{mV}$ Cal HI Value	Raw A/D Count Value <sup>3</sup>
40068	67 (0043)	CH2 $\pm 313\text{mV}$ Cal LO Value	Raw A/D Count Value <sup>3</sup>
40069	68 (0044)	CH2 $\pm 156\text{mV}$ Cal HI Value	Raw A/D Count Value <sup>3</sup>
40070	69 (0045)	CH2 $\pm 156\text{mV}$ Cal LO Value	Raw A/D Count Value <sup>3</sup>
40071	70 (0046)	CH2 $\pm 78\text{mV}$ Cal HI Value	Raw A/D Count Value <sup>3</sup>
40072	71 (0047)	CH2 $\pm 78\text{mV}$ Cal LO Value	Raw A/D Count Value <sup>3</sup>
40073	72 (0048)	CH3 0-20mA Cal HI Value (DI-913MB)	Raw A/D Count Value <sup>3</sup>
40073	72 (0048)	CH3 $\pm 10\text{V}$ Cal HI Value (DI-914MB)	Raw A/D Count Value <sup>3</sup>
40074	73 (0049)	CH3 0-20mA Cal LO Value (DI-913MB)	Raw A/D Count Value <sup>3</sup>
40074	73 (0049)	CH3 $\pm 10\text{V}$ Cal LO Value (DI-914MB)	Raw A/D Count Value <sup>3</sup>
40075	74 (004A)	CH3 4-20mA Cal HI Value (DI-913MB)	Raw A/D Count Value <sup>3</sup>
40075	74 (004A)	CH3 $\pm 5\text{V}$ Cal HI Value (DI-914MB)	Raw A/D Count Value <sup>3</sup>
40076	75 (004B)	CH3 4-20mA Cal LO Value (DI-913MB)	Raw A/D Count Value <sup>3</sup>
40076	75 (004B)	CH3 $\pm 5\text{V}$ Cal LO Value (DI-914MB)	Raw A/D Count Value <sup>3</sup>
40077	76 (004C)	CH30-11.17mA Cal HI Value (DI-913MB)	Raw A/D Count Value <sup>3</sup>
40077	76 (004C)	CH3 $\pm 2.5\text{V}$ Cal HI Value (DI-914MB)	Raw A/D Count Value <sup>3</sup>
40078	77 (004D)	CH30-11.17mA Cal LO Value (DI-913MB)	Raw A/D Count Value <sup>3</sup>
40078	77 (004D)	CH3 $\pm 2.5\text{V}$ Cal LO Value (DI-914MB)	Raw A/D Count Value <sup>3</sup>
40079	78 (004E)	CH30-1mA Cal HI Value (DI-913MB)	Raw A/D Count Value <sup>3</sup>
40079	78 (004E)	CH3 $\pm 1.25\text{V}$ Cal HI Value (DI-914MB)	Raw A/D Count Value <sup>3</sup>
40080	79 (004F)	CH30-1mA Cal LO Value (DI-913MB)	Raw A/D Count Value <sup>3</sup>
40080	79 (004F)	CH3 $\pm 1.25\text{V}$ Cal LO Value (DI-914MB)	Raw A/D Count Value <sup>3</sup>
40081	80 (0050)	CH3 $\pm 625\text{mV}$ Cal HI Value	Raw A/D Count Value <sup>3</sup>
40082	81 (0051)	CH3 $\pm 625\text{mV}$ Cal LO Value	Raw A/D Count Value <sup>3</sup>
40083	82 (0052)	CH3 $\pm 313\text{mV}$ Cal HI Value	Raw A/D Count Value <sup>3</sup>
40084	83 (0053)	CH3 $\pm 313\text{mV}$ Cal LO Value	Raw A/D Count Value <sup>3</sup>

Ref	Addr.	Description	Data Type/Format
40085	84 (0054)	CH3 $\pm 156\text{mV}$ Cal HI Value	Raw A/D Count Value <sup>3</sup>
40086	85 (0055)	CH3 $\pm 156\text{mV}$ Cal LO Value	Raw A/D Count Value <sup>3</sup>
40087	86 (0056)	CH3 $\pm 78\text{mV}$ Cal HI Value	Raw A/D Count Value <sup>3</sup>
40088	87 (0057)	CH3 $\pm 78\text{mV}$ Cal LO Value	Raw A/D Count Value <sup>3</sup>
40089	88 (0058)	0-20mA Cal HI Value (DI-913MB)	Raw A/D Count Value <sup>3</sup>
40089	88 (0058)	$\pm 10\text{V}$ Cal HI Value (DI-914MB)	Raw A/D Count Value <sup>3</sup>
40090	89 (0059)	0-20mA Cal LO Value (DI-913MB)	Raw A/D Count Value <sup>3</sup>
40090	89 (0059)	$\pm 10\text{V}$ Cal LO Value (DI-914MB)	Raw A/D Count Value <sup>3</sup>
40091	90 (005A)	4-20mA Cal HI Value (DI-913MB)	Raw A/D Count Value <sup>3</sup>
40091	90 (005A)	$\pm 5\text{V}$ Cal HI Value (DI-914MB)	Raw A/D Count Value <sup>3</sup>
40092	91 (005B)	4-20mA Cal LO Value (DI-913MB)	Raw A/D Count Value <sup>3</sup>
40092	91 (005B)	$\pm 5\text{V}$ Cal LO Value (DI-914MB)	Raw A/D Count Value <sup>3</sup>
40093	92 (005C)	0-11.17mA Cal HI Value (DI-913MB)	Raw A/D Count Value <sup>3</sup>
40093	92 (005C)	$\pm 2.5\text{V}$ Cal HI Value (DI-914MB)	Raw A/D Count Value <sup>3</sup>
40094	93 (005D)	0-11.17mA Cal LO Value (DI-913MB)	Raw A/D Count Value <sup>3</sup>
40094	93 (005D)	$\pm 2.5\text{V}$ Cal LO Value (DI-914MB)	Raw A/D Count Value <sup>3</sup>
40095	94 (005E)	0-1mA Cal HI Value (DI-913MB)	Raw A/D Count Value <sup>3</sup>
40095	94 (005E)	$\pm 1.25\text{V}$ Cal HI Value (DI-914MB)	Raw A/D Count Value <sup>3</sup>
40096	95 (005F)	0-1mA Cal LO Value (DI-913MB)	Raw A/D Count Value <sup>3</sup>
40096	95 (005F)	$\pm 1.25\text{V}$ Cal LO Value (DI-914MB)	Raw A/D Count Value <sup>3</sup>
40097	96 (0060)	$\pm 625\text{mV}$ Cal HI Value (DI-914MB)	Raw A/D Count Value <sup>3</sup>
40098	97 (0061)	$\pm 625\text{mV}$ Cal LO Value (DI-914MB)	Raw A/D Count Value <sup>3</sup>
40099	98 (0062)	$\pm 313\text{mV}$ Cal HI Value (DI-914MB)	Raw A/D Count Value <sup>3</sup>
40100	99 (0063)	$\pm 313\text{mV}$ Cal LO Value (DI-914MB)	Raw A/D Count Value <sup>3</sup>
40101	100 (0064)	$\pm 156\text{mV}$ Cal HI Value (DI-914MB)	Raw A/D Count Value <sup>3</sup>
40102	101 (0065)	$\pm 156\text{mV}$ Cal LO Value (DI-914MB)	Raw A/D Count Value <sup>3</sup>

Ref	Addr.	Description	Data Type/Format
40103	102 (0066)	±78mV Cal HI Value (DI-914MB)	Raw A/D Count Value <sup>3</sup>
40104	103 (0067)	±78mV Cal LO Value (DI-914MB)	Raw A/D Count Value <sup>3</sup>

**Notes (Register Map):**

- Note that the Report Slave ID and Reset Slave functions do not operate on Register Map locations.
- Configuration variables stored in holding registers (4xxxx reference addresses) are maintained in EEPROM, except for the Calibration Access & Reset Register. Changes to these registers do not take effect until the next software or power-on reset of the module.
- The DI-914MB A/D Count value is calculated via the expression:  $count = (32768 * V_{in} * Gain / V_{ref}) + 32768$ , where  $V_{ref} = 1.235V$ . Gain is 1 (±10V range), 2 (±5V), 4 (±2.5V), 8 (±1.25V), 16 (±625mV), 32 (±313mV), 64 (±156mV), and 128 (±78mV).  
The DI-913MB A/D Count value is calculated via the expression:  $count = (32768 * I_{in} * 49.9\Omega * Gain / V_{ref}) + 32768$ , where  $V_{ref} = 1.235V$ . Gain is 1 (0-20mA & 4-20mA range), 2 (0-11.17mA range), or 16 (0-1mA range).
- WARNING: Access to calibration registers 40025 through 40104 is not normally required and writes to these registers should be avoided to prevent module miscalibration.
- Input values are 16-bit signed integer values representing percent with a resolution of 0.005%/lsb. ±20000 is used to represent ±100%. The full range is -163.84% (-32768 decimal) to +163.835% (+32767 decimal). For example, -100%, 0% and +100% are represented by decimal values -20000, 0, and +20000, respectively. Bipolar voltage ranges (DI-914MB) use ±100% (span of -20000 to +20000), current ranges (DI-913MB) use 0-100% (span of 0 to 20000). Default limit values are set to the input range endpoints: -100% on DI-914MB (Low Limit, -20000), 0% on DI-913MB (Low Limit, 0), and +100% (High Limit, +20000). Default deadband is set to 1% (200 on DI-914MB, 100 on DI-913MB). Limit checking is always active.



# 5. An Introduction to Modbus

The Modbus protocol provides an industry standard method that Series DI-900MB modules use for parsing messages. Modbus devices communicate using a master-slave technique in which only one device (the master) can initiate transactions (called queries). The other devices (slaves) respond by supplying the requested data to the master, or by taking the action requested in the query. The Series DI-900MB modules are slaves, while a typical master device is a host computer running appropriate application software. Masters can address individual slaves, or can initiate a broadcast message to all slaves. Slaves return a response to all queries that are addressed to them individually, but no response is returned to broadcast queries from a master device.

## Remote Terminal Unit (RTU) Mode

The Series DI-900MB modules use the widely accepted Modbus network protocol in the RTU (Remote Terminal Unit) serial transmission mode. In RTU mode, each 8-bit message byte contains two 4-bit hexadecimal characters, and the message is transmitted in a continuous stream. The format for each byte in RTU mode is outlined below:

### RTU Mode Byte Format

Coding System	8-bit binary, hexadecimal 0-9, A-F, two hexadecimal characters contained in each 8-bit field of the message.
Bits Per Byte	1 start bit + 8 data bits, lsb sent first + 1bit for even/odd parity or no bit for no parity + 1 stop bit if parity is used or 2 stop bits with no parity.
Error Check Field	Cyclical Redundancy Check (CRC)

A master's query is comprised of a slave address (or broadcast address), a function code defining the requested action, any required data, and an error checking field. A slave's response is comprised of fields confirming the action taken, any data to be returned, and an error checking field.

The query and response both include a device address + function code + data byte(s) + error checking field. If an error occurred in the receipt of the query, or if the slave is unable to perform the requested action, the slave will return an exception message as its response (see Modbus Exceptions). The error check field allows the master to confirm that the message contents are valid.

## Modbus Message Framing

A Modbus message is placed in a frame by the transmitting device. A frame is used to mark the beginning and ending point of a message allowing the receiving device to determine which device is being addressed and to know when the message is completed. It also allows partial messages to be detected and errors flagged as a result.

RTU mode messages start with a silent interval of at least 3.5 character times implemented as a multiple of character times at the baud rate being used on the network (indicated as t1t2t3t4 below). The first field transmitted is the device address. The allowable characters transmitted for all fields are hexadecimal values 0-9, A-F. A networked device continuously monitors the network, including the silent intervals, and when the first field is received (the address), the device decodes it to determine if it is the addressed device. Following the last character transmitted, a similar silent interval of 3.5 character times marks the end of the message and a new message can begin after this interval. A typical message frame is shown below.

### RTU Message Frame

Start	Addr.	Function	Data	CRC	End
t1t2t3t4	8 bits	8 bits	nx8 bits	16 bits	t1t2t3t4

The entire message must be transmitted as a continuous stream. If a silent interval of more than 1.5 character times occurs before completion of the frame, the receiving device flushes the incomplete message and assumes the next byte will be the address field of a new message.

In similar fashion, if a new message begins earlier than 3.5 character times following a previous message, the receiving device assumes it is a continuation of the previous message. This will generate an error, as the value in the final CRC field will not be valid for the combined messages.

## How Characters Are Transmitted Serially

When messages are transmitted on Modbus serial networks, each character or byte is sent in the order of Least Significant Bit (LSB) to Most Significant Bit (MSB) as outlined below (left to right):

### RTU Character Framing (No Parity)

Start	0	1	2	3	4	5	6	7	Stop	Stop
-------	---	---	---	---	---	---	---	---	------	------

### RTU Character Framing (With Parity)

Start	0	1	2	3	4	5	6	7	Parity	Stop
-------	---	---	---	---	---	---	---	---	--------	------

Note that an additional stop bit is transmitted to fill out the character frame for no parity.

## Modbus Addresses

The master device addresses a specific slave device by placing the 8-bit slave address in the address field of the message. Valid addresses are from 1-247. When the slave responds, it places its own address in this field of its response to let the master know which slave is responding. Address 0 is reserved for the broadcast address, which all slave devices on a network recognize. A slave does not issue a response to broadcast messages. Further, not all function messages support the broadcast address.

With respect to data addresses, all data addresses in Modbus messages are referenced to 0, with the first occurrence of a data item addressed as item number zero. Further, a function code field already specifies which register group it is to operate on (i.e. 0x, 1x, 3x, or 4x reference addresses). For example, holding register 40001 is addressed as register 0000 in the data address field of the message. The function code that operates on this register specifies a “holding register” operation and the “4xxxx” reference is implied. Holding register 40108 is addressed as register 006BH (107 decimal).

## Modbus Functions

The function code field of a message frame contains the 8 bits that tell the slave what kind of action to take. Valid codes are in the range 1-255. Not all codes apply to a module and some codes are reserved for future use. The following table highlights the subset of standard Modbus functions supported by the Model DI-913MB/DI-914MB module (the reference register addresses that the function operates on are also indicated):

Code	Function	Reference
01 (01H)	Read Coil (Output) Status	0xxxx
03 (03H)	Read Holding Registers	4xxxx
04 (04H)	Read Input Registers	3xxxx
05 (05H)	Force Single Coil (Output)	0xxxx
06 (06H)	Preset Single Register	4xxxx
08 (08H)	Reset Slave	Hidden
15 (0FH)	Force Multiple Coils (Outputs)	0xxxx
16 (10H)	Preset Multiple Registers	4xxxx
17 (11H)	Report Slave ID	Hidden

These functions are used to access the registers outlined in the Register Map for sending and receiving data. Note that the Report Slave ID and Reset Slave commands do not operate on register map registers.

When the slave device responds to the master, it uses the function code field to indicate either a normal (error-free) response, or that some kind of error has occurred (an exception response). A normal response simply echoes the original function code of the query, while an exception response returns a code that is equivalent to the original function code with its most significant bit (msb) set to a logic 1. For example, the Read Holding Registers command has the function code 0000 0011 (03H). If the slave device takes the requested action without error, it returns the same code in its response. However, if an exception occurs, it returns 1000 0011 (83H) in the function code field and also appends a unique code in the data field of the response message that tells the master device what kind of error occurred, or the reason for the exception (See Modbus Exceptions). The master's application program must handle the exception response. It may choose to post subsequent retries of the original message, it may try sending diagnostic messages to the slave, or it may simply notify the operator an exception error has occurred.

The following paragraphs describe the Modbus functions supported by this model. To gain a better understanding of Modbus, please refer to the Register Map as you review this material.

### Read Coil Status (01)

This command will read the ON/OFF status of discrete outputs or coils (0x reference addresses) in the slave. For DI-913MB/DI-914MB models, its response is equivalent to reading the gate signals of the n-channel mosfets that drive the outputs. Broadcast transmission is not supported.

The Read Coil Status query specifies the starting coil (output channel) and quantity of coils to be read. Coils correspond to the discrete open-drain outputs of this transmitter and are addressed starting from 0 (up to 4 coils addressed as 0-3 for this model).

The Read Coil Status in the response message is packed as one coil or channel per bit of the data field. The output status is indicated as 1 for ON (sinking current), and 0 for OFF (not conducting). The LSB of the first data byte corresponds to the status of the coil addressed in the query. The other coils follow sequentially, moving toward the high order end of the byte. Since this model has only 4 outputs, the remaining bits of the data byte will be set to zero toward the unused high order end of the byte.

The following example reads the output channel status of coils 0-3 at slave device 247:

**Read Coil Status Example Query**

Field Name	Example Value (Hex)
Slave Address	247 (F7)
Function Code	1 (01)
Starting Address High Order	0 (00)
Starting Address Low Order	0 (00)
Number Of Points High Order	0 (00)
Number Of Points Low Order	4 (04)
Error Check (LRC or CRC)	--

**Read Coil Status Example Response**

Field Name	Example Value (Hex)
Slave Address	247 (F7)
Function Code	1 (01)
Byte Count	1 (01)
Data (Coils 3-0)	10 (0A)
Error Check (LRC or CRC)	--

Note that the leading character of the 0x reference address is implied by the function code and omitted from the address specified. In this example, the first address is 00001, referenced via 0000H, and corresponding to coil 0.

To summarize, the status of coils 3-0 is shown as the byte value 0A hex, or 00001010 binary. Coil 3 is the fifth bit from the left of this byte, and coil 0 is the LSB. The four remaining bits (toward the high-order end) are zero. Reading left to right, the output status of coils 3..0 is ON-OFF-ON-OFF. This is summarized as follows:

<b>Bin</b>	0	0	0	0	1	0	1	0
<b>Hex</b>	0				A			
<b>Coil</b>	NA	NA	NA	NA	3	2	1	0

### Read Holding Registers (03)

This command will read the binary contents of holding registers (4x reference addresses) in the slave device. Broadcast transmission is not supported.

The Read Holding Registers query specifies the starting register and quantity of registers to be read. Note that registers are addressed starting at 0 (registers 1-16 addressed as 0-15). The Read Holding Registers response message is packed as two bytes per register, with the binary contents right-justified in each byte. For each register, the first byte contains the high order bits and the second byte the low order bits.

The following example reads holding registers 40006...40008 (Channel 0 high limit value, low limit value, deadband value) at slave device 247:

**Read Holding Register Example Query**

Field Name	Example Value (Hex)
Slave Address	247 (F7)
Function Code	3 (03)
Starting Address High Order	0 (00)
Starting Address Low Order	5 (05)
Number Of Points High Order	0 (00)
Number Of Points Low Order	3 (03)
Error Check (LRC or CRC)	--

**Read Holding Register Example Response**

Field Name	Example Value (Hex)
Slave Address	247 (F7)
Function Code	3 (03)
Byte Count	6 (06)
Data High (Register 40006)	(3A)
Data Low (Register 40006)	75%=15000 (98)
Data High (Register 40007)	(13)
Data Low (Register 40007)	25%=5000 (88)
Data High (Register 40008)	(00)
Data Low (Register 40008)	1%=200 (C8)
Error Check (LRC or CRC)	--

To summarize, the contents of register 40006 (two bytes) is the channel 0 high limit of 75% (15000=3A98H). The contents of register 40007 (two bytes) is the channel 0 low limit of 25% (5000=1388H). The contents of register 40008 is the channel 0 deadband value (two bytes) of 1% (200=00C8H).

### Read Input Registers (04)

This command will read the binary contents of input registers (3x reference addresses) in the slave device. Broadcast transmission is not supported.

The Read Input Registers query specifies the starting register and quantity of registers to be read. Note that registers are addressed starting at 0--registers 1-16 are addressed as 0-15.

The Read Input Registers response message is packed as two bytes per register, with the binary contents right-justified in each byte. For each register, the first byte contains the high order bits and the second byte the low order bits.

The following example reads input registers 30003 & 30004 (Channel 0 input value and status) at slave device 247:

**Read Input Register Example Query**

Field Name	Example Value (Hex)
Slave Address	247 (F7)
Function Code	4 (04)
Starting Address High Order	0 (00)
Starting Address Low Order	2 (02)
Number Of Points High Order	0 (00)
Number Of Points Low Order	2 (02)
Error Check (LRC or CRC)	--

**Read Input Register Example Response**

Field Name	Example Value (Hex)
Slave Address	247 (F7)
Function Code	4 (04)
Byte Count	4 (04)
Data High (Register 30003)	(3E)
Data Low (Register 30003)	80%=16000 (80)
Data High (Register 30004)	(00)
Data Low (Register 30004)	136 (88)
Error Check (LRC or CRC)	--

To summarize, the contents of register 30003 (two bytes) is the channel 1 input value of 80% (16000=3E80H). The contents of register 30004 (two bytes) is the channel 0 status flags of 136 (0088H)-i.e. flagging high limit exceeded.

### **Force Single Coil (05)**

This command will force a single coil/output (ox reference address) ON or OFF. For broadcast transmission, this function forces the same coil in all networked slaves.

The Force Single Coil query specifies the coil reference address to be forced, and the state to force it to. The ON/OFF state is indicated via a constant in the query data field. A value of FF00H forces the coil to be turned ON (i.e. the gate of the corresponding n-channel mosfet is set high), and 0000H forces the coil to be turned OFF (i.e. the gate of the corresponding output mosfet is set low). All other values are illegal and will not affect the coil. Note that coils are referenced starting at 0-up to 4 coils are addressed as 0-3 for this model and this corresponds to the discrete output channel number. The following example forces discrete output 3 ON at slave device 247:

**Force Single Coil Example Query**

Field Name	Example Value (Hex)
Slave Address	247 (F7)
Function Code	5 (05)
Coil Address High Order	0 (00)
Coil Address Low Order	3 (03)
Force Data High Order	255 (FF)
Force Data Low Order	0 (00)
Error Check (LRC or CRC)	--

**Force Single Coil Example Response**

Field Name	Example Value (Hex)
Slave Address	247 (F7)
Function Code	5 (05)
Coil Address High Order	0 (00)
Coil Address Low Order	3 (03)
Force Data High Order	255 (FF)
Force Data Low Order	0 (00)
Error Check (LRC or CRC)	--

The Force Single Coil response message is an echo of the query as shown above, returned after executing the force coil command. No response is returned to broadcast queries from a master device.

### **Preset Single Register (06)**

This command will preset a single holding register (4x reference addresses) to a specific value. Broadcast transmission is supported by this command and will act to preset the same register in all networked slaves.

The Preset Single Register query specifies the register reference address to be preset, and the preset value. Note that registers are addressed starting at 0--registers 1-16 are addressed as 0-15.

The Preset Single Registers response message is an echo of the query, returned after the register contents have been preset.

The following example writes a baud rate of 9600bps to holding register 40002 (Baud Rate) at slave device 247:

**Preset Holding Register Example Query**

Field Name	Example Value (Hex)
Slave Address	247 (F7)
Function Code	6 (06)
Register Address High Order	0 (00)
Register Address Low Order	1 (01)
Preset Data High Order	0 (00)
Preset Data Low Order	2 (02)
Error Check (LRC or CRC)	--

**Preset Holding Register Example Response**

Field Name	Example Value (Hex)
Slave Address	247 (F7)
Function Code	6 (06)
Register Address High Order	0 (00)
Register Address Low Order	1 (01)
Preset Data High Order	0 (00)
Preset Data Low Order	2 (02)
Error Check (LRC or CRC)	--

The response simply echoes the query after the register contents have been preset. No response is returned to broadcast queries from a master device.

### Force Multiple Coils (15)

This command will simultaneously force a sequence of coils (0x reference addresses) either ON or OFF. Broadcast transmission is supported by this command and will act to force the same block of coils in all networked slaves.

The Force Multiple Coils query specifies the starting coil reference address to be forced, the number of coils, and the force data to be written in ascending order. The ON/OFF states are specified by the contents in the query data field. A logic 1 in a bit position of this field requests that the coil turn ON, while a logic 0 requests that the corresponding coil be turned OFF. Unused bits in a data byte should be set to zero. Note that coils are referenced starting at 0-up to 4 coils are addressed as 0-3 for this model and this also corresponds to the discrete output channel number.

The Force Multiple Coils normal response message returns the slave address, function code, starting address, and the number of coils forced, after executing the force instruction. Note that it does not return the byte count or force value. The following example forces outputs 1 & 3 OFF, and 0 & 2 ON for coils 0-3 at slave device 247:

#### Force Multiple Coils Example Query

Field Name	Example Value (Hex)
Slave Address	247 (F7)
Function Code	15 (0F)
Coil Address High Order	0 (00)
Coil Address Low Order	0 (00)
Number Of Coils High Order	0 (00)
Number Of Coils Low Order	4 (04)
Byte Count	01
Force Data High (First Byte)	5 (05)
Error Check (LRC or CRC)	--

Note that the leading character of the 0x reference address is implied by the function code and omitted from the address specified.

In this example, the first address is 00001 corresponding to coil 0 and referenced via 0000H. Thus, the data byte transmitted will address coils 3...0, with the least significant bit addressing the lowest coil in this set as follows (note that the four unused upper bits of the data byte are set to zero):

<b>Bin</b>	0	0	0	0	0	1	0	1
<b>Hex</b>	0				5			
<b>Coil</b>	NA	NA	NA	NA	3	2	1	0

#### Force Multiple Coils Example Response

Field Name	Example Value (Hex)
Slave Address	247 (F7)
Function Code	15 (0F)
Coil Address High Order	0 (00)
Coil Address Low Order	0 (00)
Number Of Coils High Order	0 (00)
Number Of Coils Low Order	4 (04)
Error Check (LRC or CRC)	--

The normal response returns the slave address, function code, starting coil address, and quantity of coils forced, after executing the force instruction. It does not return the byte count or force data. No response is returned to broadcast queries from a master device.

### **Preset Multiple Registers (16)**

This command will preset a block of holding registers (4x reference addresses) to specific values. Broadcast transmission is supported by this command and will act to preset the same block of registers in all networked slaves.

The Preset Multiple Registers query specifies the starting register reference address, the number of registers, and the data to be written in ascending order. Note that registers are addressed starting at 0--registers 1-16 are addressed as 0-15.

The Preset Multiple Registers normal response message returns the slave address, function code, starting register reference, and the number of registers preset, after the register contents have been preset. Note that it does not echo the preset values.

The following example writes a new slave address of 200, a baud rate of 28800bps, and sets parity to even, by writing to holding registers 40001 through 40003 at slave device 247 (changes to slave address, baud rate, and parity will take effect following the next software or power-on reset):

**Preset Multiple Registers Example Query**

Field Name	Example Value (Hex)
Slave Address	247 (F7)
Function Code	16 (10)
Starting Register High Order	0 (00)
Starting Register Low Order	0 (00)
Number Of Registers High Order	0 (00)
Number Of Registers Low Order	3 (03)
Preset Data High (First Register)	0 (00)
Preset Data Low (First Register)	200 (C8)
Preset Data High (Second Reg)	0 (00)
Preset Data Low (Second Reg)	5 (05)
Preset Data High (Third Reg)	0 (00)
Preset Data Low (Third Reg)	2 (02)
Error Check (LRC or CRC)	--

**Preset Multiple Registers Example Response**

Field Name	Example Value (Hex)
Slave Address	247 (F7)
Function Code	16 (10)
Starting Register High Order	0 (00)
Starting Register Low Order	0 (00)
Number Of Registers High Order	0 (00)
Number Of Registers Low Order	3 (03)
Error Check (LRC or CRC)	--

The response simply echoes the query without returning the preset values after the register contents have been preset. No response is returned to broadcast queries from a master device.

### **Report Slave ID (17)**

This command returns the model number, serial number, and firmware number for a slave device, the status of the Run indicator, and any other information specific to the device.

This command does not address Register Map registers. Broadcast transmission is not supported.

The Report Slave ID query simply sends the slave address and function code with error check (CRC) as follows:

**Report Slave ID Example Query**

Field Name	Example Value (Hex)
Slave Address	247 (F7)
Function Code	17 (11)
Error Check (LRC or CRC)	--

**Report Slave ID Example Response**

Field Name	Example Value (Hex)
Slave Address	247 (F7)
Function Code	17 (11)
Byte Count	26 (1A)

Slave ID	0 (00H) = 924MB-0900 1 (01H) = 913MB-0900 2 (02H) = 914MB-0900 3 (03H) = 917MB-0900 4 (04H) = 918MB-0900 5 (05H) = 901MB-0900 6 (06H) = 902MB-0900 7 (07H) = 903MB-0900 8 (08H) = 904MB-0900 9 (09H) = 905MB-0900 10 (0AH) = 906MB-0900
Run Indicator Status (ON)	255 (FF)
Firmware Number ASCII Byte String (Additional Data Field)	"ACROMAG,9300-036A, 913MB-0900,"(41 43 52 4F 4D 41 47 2C 39 33 30 30 2D 30 33 36 41 2C 39 31 33 4D 42 2D 30 39 30 30 2CH)
Serial Number ASCII Byte String (Unique Per Module)	Six Numbers + Revision"123456A"(31 32 33 34 35 36 41H)
Error Check (LRC or CRC)	--

The Report Slave ID response message returns the slave model ID and firmware number string as shown above.

### Reset Slave (08)

This command is used to trigger a reset of the module and its effect is equivalent to a power-on reset of the module. Note that changes to baud rate, slave address, and parity are initiated following reset.

The Reset Slave command uses sub-function 01 (Restart Communications) of the standard Modbus Diagnostics Command (08) to accomplish a module reset. This function does not operate on register map locations. Broadcast transmission is not supported.

The Reset Slave query simply sends the slave address, function code, sub-function code, and data (data is ignored and simply echoed back), with error check (CRC). A Reset Slave response is simply an echoed acknowledge that is returned just before the reset is executed. Allow a few seconds following reset to re-initiate communication with a module.

#### Reset Slave Example Query

Field Name	Example Value (Hex)
Slave Address	247 (F7)
Function Code	08 (08)
Sub-Function High Order Byte	0 (00)
Sub-Function Low Order Byte	1 (01)
Data Field High-Order Byte	0 (00)
Data Field Low Order Byte	0 (00)
Error Check (LRC or CRC)	--

#### Reset Slave Example Response (Sent Prior To Reset)

Field Name	Example Value (Hex)
Slave Address	247 (F7)
Function Code	08 (08)
Sub-Function High Order Byte	0 (00)
Sub-Function Low Order Byte	1 (01)
Data Field High-Order Byte	0 (00)
Data Field Low Order Byte	0 (00)
Error Check (LRC or CRC)	--

For Modbus software that does not support the Reset Slave function, an alternate method of generating a module reset is provided via a write to the Calibration Access & Module Reset Register (See Register 4001 of Register Map).



## Modbus Data Field

The data field of a message frame contains a multiple of 8 bits that provides the slave with any additional information the slave requires to complete the action specified by the function code. The data field typically includes register addresses, count values, and written data. The data field can be nonexistent for some commands (zero length), as not all messages require data.

If no error occurs, the data field of a response from a slave will return the requested data. If an error occurs, the data field returns an exception code (see Modbus Exceptions) that the master application can use to determine the next action to take.

## Supported Data Types

All I/O values are accessed via 16-bit Input Registers or 16-bit Holding Registers (see Register Map). Input registers contain information that is read-only. For example, the current input value read from a channel, or the states of a group of digital inputs. Holding registers contain read/write information that may be configuration data or output data. For example, the high limit value of an alarm function operating at an input, or an output value for an output channel. I/O values for this model are represented by the following simple data types for temperature, percentage, and discrete on/off.

### Summary Of Data Types Used By DI-900MB Modules

Data Types	Description
Count Value	A 16-bit signed integer value representing an A/D count, a DAC count, or a time value with a range of -32768 to +32767.
Percentage	A 16-bit signed integer value with resolution of 0.005%/lsb. $\pm 20000$ is used to represent $\pm 100\%$ . For example, -100%, 0% and +100% are represented by decimal values -20000, 0, and 20000, respectively. The full range is -163.84% (-32768 decimal) to +163.835% (+32767 decimal).
Temperature	A 16-bit signed integer value with resolution of 0.1°C/lsb. For example, a value of 12059 is equivalent to 1205.9°C, a value of -187 equals -18.7°C. The maximum possible temperature range is -3276.8°C to +3276.7°C.
Discrete	A discrete value is generally indicated by a single bit of a 16-bit word. The bit number/position typically corresponds to the discrete channel number for this model. Unless otherwise defined for outputs, a 1 bit means the corresponding output is closed or ON, a 0 bit means the output is open or OFF. For inputs, a value of 1 means the input is in its high state (usually $\gg 0V$ ), while a value of 0 specifies the input is in its low state (near 0V).

## Modbus Error Checking Fields

Modbus networks employ two methods of error checking: parity checking (even or odd parity, or none), and frame checking (Cyclical Redundancy Check).

### Parity Checking

A Modbus device can be configured for Even or Odd parity checking, or for no parity checking, and this determines how the parity bit of the data frame is set.

If even or odd parity checking is selected, the number of 1 bits in the data portion of each character frame is counted. Each character in RTU mode contains 8 bits. The parity bit will then be set to a 0 or a 1, to result in an even (Even parity), or odd (Odd parity) total number of 1 bits. For example, if an RTU character frame contains the following eight data bits: 1100 0011, then since the total number of 1 bits is 4 (already an even number), the frame's parity bit will be 0 if even parity is selected. If odd parity is used, then the parity bit will be set to 1, making the total number of bits an odd number (five).

When a message is transmitted, the parity bit is calculated and applied to the frame of each character transmitted. The receiving device counts the quantity of 1 bits in the data portion of the frame and sets an error flag if the count differs

from that sent. As such, parity checking can only detect an error if an odd number of bits are picked up or dropped off from a character frame during transmission. For example, if odd parity is employed and two 1 bits are dropped from a character, the result is still an odd count of 1 bits. Note that all devices on a Modbus network must use the same parity.

If no parity checking is selected, then no parity bit is transmitted and no parity check is made. An additional stop bit is transmitted to fill out the character frame for the no parity selection.

## CRC Error Checking

RTU Mode message frames include an error checking method that is based on a Cyclical Redundancy Check (CRC). The error checking field of a frame contains a 16-bit value (two 8-bit bytes) that contain the result of a Cyclical Redundancy Check (CRC) calculation performed on the message contents.

The CRC value is calculated by the transmitting device and is appended to the message as the last field in a message--the low order byte is appended first, followed by the high-order byte. Thus, the CRC high-order byte is the last byte to be sent in a message. The receiving device calculates a CRC during receipt of a message and compares the calculated value to that received in the CRC field. If the two values differ, an error results.

The CRC is started by first preloading the 16-bit CRC register to all 1's. Successive 8-bit bytes of the message (only the 8-data bits in each character--no start, stop, or parity bits) are applied to the current contents of the register, and each 8-bit character is exclusive OR'ed with the register contents. The exclusive OR result is shifted in the direction of the least significant bit (lsb) of the CRC, with a zero placed into the most significant bit (msb). The lsb is then extracted and examined, if the lsb is a 1, the register is exclusive OR'ed with a preset fixed value. If the lsb is a 0, no exclusive OR takes place. This process is repeated until 8 shifts have been performed. After the last (eighth) shift, the next 8-bit byte is exclusive OR'ed with the register's current contents, and the process repeats itself for 8 more shifts as described above. The final contents of the CRC register after all the message bytes have been applied is the CRC value.

## Modbus Exceptions

If an unsupported function code is sent to a module, then the exception code 01 (Illegal Function) will be returned in the data field of the response message. If a holding register is written with an invalid value, then exception code 03 (Illegal Data Value) will be returned in the response message. The following table lists possible exception codes:

**Modbus Exception Codes**

Code	Exception	Description
01	Illegal Function	The function code received in the query is not allowed or invalid.
02	Illegal Data Address	The data address received in the query is not an allowable address for the slave or is invalid.
03	Illegal Data Value	A value contained in the query data field is not an allowable value for the slave or is invalid.
04	Slave Device Failure	An unrecoverable error occurred while the slave was attempting to perform the requested action.
05	Acknowledge	The slave has accepted the request and is processing it, but a long duration of time is required to do so. This response is returned to prevent a timeout error from occurring in the master.
06	Slave Device Busy	The slave is engaged in processing a long-duration program command. The master should retransmit the message later when the slave is free.
07	Negative Acknowledge	The slave cannot perform the program function received in the query. This code is returned for an unsuccessful programming request using function code 13 or 14 (codes not supported by this model). The master should request diagnostic information from the slave.

---

08	Memory Parity Error	The slave attempted to read extended memory, but detected a parity error in memory. The master can retry the request, but service may be required at the slave device.
----	---------------------	--

In a normal response, the slave echoes the function code of the original query in the function field of the response. All function codes have their most-significant bit (msb) set to 0 (their values are below 80H). In an exception response, the slave sets the msb of the function code to 1 in the returned response (i.e. exactly 80H higher than normal) and returns the exception code in the data field. This is used by the master's application to recognize an exception response and to direct an examination of the data field for the applicable exception code.



# 6. Module Software Configuration

From the factory, each module has a default configuration as detailed in the Module Installation section of this manual. Your application will likely differ from the default configuration and the module will need to be reconfigured. Series DI-900MB modules may be configured and calibrated by issuing the appropriate Modbus functions to the Register Map registers, as required to configure the unit. However, it is much simpler to use the DI-900MB Configuration Software to program and control the module parameters and operating modes. This software is easy to use, self-explanatory, and complete configuration takes only a few minutes. On-line help is built-in. As such, a comprehensive guide to the use of this program is not necessary. To begin configuration, you should already be familiar with Windows operation and have a basic understanding of module terminology as it relates to this model.

## Before You Begin

1. Have you installed the DI-900MB Configuration Program? You should complete the Module Installation section of this manual before proceeding.
2. Check that all necessary electrical connections have been made and that power is applied (module's green LED ON).
3. Is baud set correctly at the RS485 converter/repeater??
4. Have you tried communicating using the Default Mode? Press the "DFT" push-button of the DI-913MB/DI-914MB module until the yellow status LED is flashing. This sets the module's communication parameters to 9600 baud, a slave address of 247, no parity, and two stop bits.
5. If you fail to communicate with the module or have a high degree of communication errors, try increasing the response delay time (See Response Delay Register 40010). Some network converters or host/software systems cannot accept an immediate response from a slave without added delay.
6. Do not leave unused inputs floating, or you may experience increased measurement noise and slower update cycles. It is recommended that unused inputs be shorted by applying a jumper between IN+ and IN-.

The following sections guide you through the DI-900MB Configuration Program property sheets used to configure a DI-914MB Transmitter. The model DI-913MB is similar. Property sheets will vary somewhat from model to model, but the general approach is the same.

## Starting The Program

After clicking on the Series DI-900MB program icon to boot the Configuration Program, a screen will be displayed similar to that shown at right.

To begin, click on the “Settings-Serial Communications...” pull-down menu (or press Ctrl-E) to set the COM port, baud rate, parity, and slave address that the host computer will use to communicate with the module. Optionally, you can check the “Update Communications settings at download” box to automatically change the host settings to match the module if new settings are later downloaded to the module (recommended to conveniently maintain communication with a module following reconfiguration).

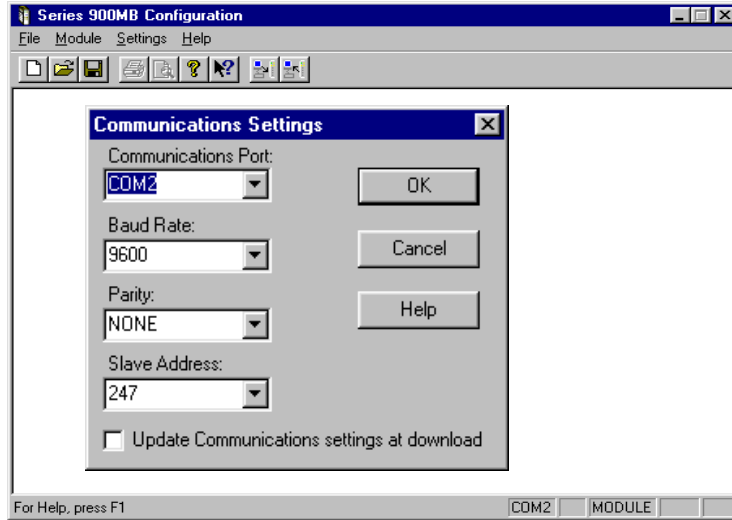

Note that the host COM port selected is indicated in the first box of the lower right-hand corner. MODULE is indicated in the third box if a connected module is detected by the software. The fourth and fifth boxes indicate NUM for Num lock and CAP for Caps lock, respectively.

### **File**

- New...
- Open...
- Save
- Save As...
- Print...
- Print Preview
- Print Setup...
- Recent File Indicated*
- Exit

Use **File-New** to create a new configuration file. You will be prompted to select a model number. Use **File-Open** to open an existing configuration file.

Use **File-Save** to save the current configuration file to disk. Use **File-Save As** to save the current configuration file to a new file name.

Use **File-Print** to get a printout of the currently loaded configuration file. Use **File-Print Preview** to view the current configuration or preview the print documentation. Use **File-Print-Setup** to select a printer and font style.

### **Module**

- Upload Configuration
- Download Configuration

Use **Module-Upload Configuration** to upload the module’s current configuration and calibration.

Use **Module-Download Configuration** to write the currently loaded configuration to the module.

### **Settings**

- Serial Communications...**
  - Communications Port
  - Host Baud Rate
  - Host Parity

### Slave Address

Use the **Communications Port** Scroll Window to select the host COM port the module is connected to (COM1-COM4), or type in a COM port as required, from COM1 to COM99. The selected COM port is indicated in the lower right-hand corner of the screen.

Use the **Baud Rate** scroll window to select the baud rate to be used by the host in communicating with the module.

Use the **Parity** scroll window to select Odd, Even, or No Parity checking by the software for data transfer.

Use the **Slave Address** scroll window to tell the software which module to address.

If you wish to maintain communications with a module following download, you should check the **“Update Communications settings at download”** box of the Settings window to keep the host in synch with a module if the module settings are changed.

If the module is in the Default Mode (indicated via a flashing status LED), the baud rate, address, and parity assumed by the module are fixed at 9600bps, 247, and No Parity. You must use the same settings as the connected module.

## Help

- Configuration **H**elp Topics
- Your Model* Help Topics
- A**bout Modbus Configuration
- About *Your Model*

Use **Help** to obtain information about using this software or configuring transmitters. Note that context sensitive help (?) is also available for help on a specific field or topic. Simply click on the [?] button, then click on the field or topic of interest to obtain help on that subject. You may also click the right mouse button to copy or print the help screen while it is being displayed.

The following sections review the configuration of a Model DI-914MB transmitter. The Model DI-913MB will be similar.

## Creating A Configuration File

You may use **File-New** to create a new configuration file, or **File-Open** to open an existing configuration file. You may also use **Module-Upload Configuration** to retrieve the current active configuration from the module connected (recommended).

Uploading first is recommended as it will automatically detect the correct model connected and load the property sheets for that model.

Once you create, open, or upload a configuration file, a screen similar to the one shown at right will be displayed. The model number is indicated at the top of the screen along with the current file name. The Model DI-914MB General screen is shown here. Your screen will vary according to your model number.

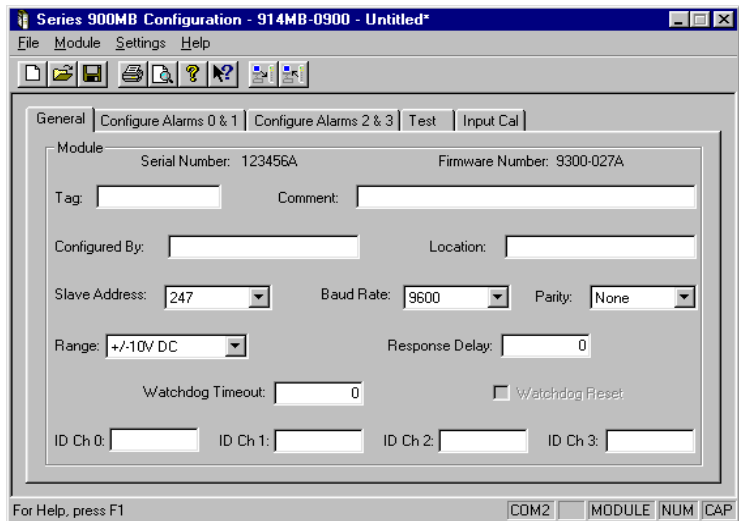

Note that 5 property sheets define this transmitter's configuration: General, Configure Alarms 0 & 1, Configure Alarms 2 & 3, Test, and Input Calibration.

## Module

The Serial and Firmware numbers are indicated at the top of the General screen and cannot be modified.

For “Tag:”, enter up to 15 alphanumeric characters (optional).

For “Comment:”, enter up to 31 alphanumeric characters (optional).

For “Configured By:”, enter your name up to 15 alphanumeric characters (optional).

You can also add a “Location:” note of up to 25 alphanumeric characters (optional).

For “Channel ID:”, enter up to 15 alphanumeric characters of identification information relative to the output channel (optional).

Use the “**Slave Address**” scroll bar to select a new module address that will take effect following download. Select from 1 to 247. Address 247 is reserved for Default Mode.

Use the “**Baud Rate**” scroll bar to select a new baud rate to be used by the module following download. Select 2400, 4800, 9600 (Default Mode), 14400, 19200, 28800, 38400, 57600, 76800, or 115200 bits per second.

Use the “**Parity**” scroll bar to select Odd, Even, or No Parity (Default Mode) error checking by the module.

Use the “**Response Delay**” field to specify a delay from 0 to 65500 ticks with 1 tick equal to 1.085 micro-seconds. Response delay is the additional turnaround delay applied between message receipt by the module and its response to the host. A fixed amount of delay is already present and varies with the model. Thus, you will have to specify a comparable amount of response delay to measure any affect. Some host software or signal converters require additional delay to work properly.

Note that slave address, baud rate, and parity selections take effect following a configuration download and do not alter the settings used by the host software (configured separately via the **Settings** menu).

If you checked the “Update Communications settings at download” box of the Settings pull-down menu, the host software will change its own settings to match the module settings that take effect following a download in an effort to maintain communication with the module. Otherwise, you must change the host Settings separately after downloading to match the new module settings.

If the module is in Default Mode (indicated via a flashing status LED), the baud rate, address, & parity of the module are fixed at 9600bps, 247, and No Parity.

**Input (Applies To All Inputs)**

Use the “**Range:**” scroll bar to pick one of the following ranges according to your model:

<u>Model DI-913MB</u>	<u>Model DI-914MB</u>
0-20mA DC (% of span)	10V DC (% of span)
4-20mA DC (% of span)	5V DC (% of span)
0-11.17mA DC (% of span)	2.5V DC (% of span)
0-1mA DC (% of span)	1.25V DC (% of span)
	625mV DC (% of span)
	313mV DC (% of span)
	156mV DC (% of span)
	78mV DC (% of span)

Note that multiple inputs of the same module must be configured for the same input type.

Available ranges will vary according to your model number. All input ranges have been factory calibrated.

To begin configuring your module, start by selecting an input range as required. Note that this module returns values in percent-of-span with 20000 representing 100%. That is, for the 10V range, 0% represents -10V (-20000), and 100% represents 10V (+20000). Scaling of 20000 to 100% is done for convenience of display in this software. Your



software may rescale these values as required for your application. Keep this in mind when using other software to communicate with the module.

If you wish to enable the I/O Watchdog Timer, specify a “**Watchdog Timeout**” delay from 1 to 65534 seconds (0 will disable timer). A watchdog timeout will occur if no I/O has occurred within this time period. You may click the “**Watchdog Reset**” check box to also send the outputs to their reset states upon watchdog timeout (Reset States are set via the Configure Alarms screens). The next section covers optional alarm configuration.

## Alarm Configuration

Clicking on the Configure Alarms property sheet tabs will display a screen similar to the one at right. The DI-914MB Alarm Configuration screen is shown here (DI-913MB is similar). Your screen will vary according to your model and selected input range.

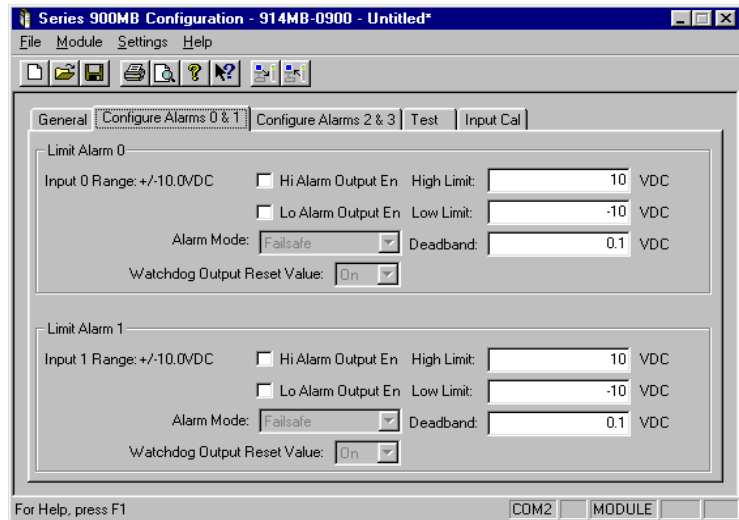

**IMPORTANT:** Limit checking is always active for the module. The default limit values are the input range endpoints. The High/Low Alarm Output Enable is used to enable the corresponding output channel as an alarm output.

You can enable the alarm outputs via the High/Low Alarm Output Enable boxes.

The default High and/or Low Limit values can be changed. Optionally, deadband may be applied to both limits. You can also specify failsafe or non-failsafe alarm outputs. Refer to the limit alarm configuration field descriptions below to complete this information for Limit Alarms 0, 1, 2, & 3.

### Alarm Config Field Descriptions

#### Limit Alarm (Each Input)

**Hi/Lo Alm Output En (Each Input):** Enable High and/or Low Limit alarm output control for each input. Limit alarm control of the corresponding output takes priority over direct control when enabled.

**High Limit (Each Input):** The high limit level is programmable over the entire input range and entered in the same engineering units as the input. The corresponding alarm output will go to its alarm state for an increasing input signal that equals or exceeds the high limit value (if enabled).

**Low Limit (Each Input):** The low limit level is programmable over the entire input range and entered in the same engineering units as the input. The corresponding alarm output will go to its alarm state for a decreasing input signal that equals or goes below the low limit value (if enabled).

**Deadband (Each Input):** Deadband may be applied to both limit levels and is programmable over the entire input range. Deadband is entered in the same units as the input and determines the amount the input signal has to return into the “normal” operating range before the corresponding open-drain alarm output will transfer out of the “alarm” state. Deadband is normally used to eliminate false trips or switch “chatter” caused by fluctuations of the input near the limit.

**Alarm Mode (Each Input):** This field allows you to select failsafe or non-failsafe alarm output activation. A failsafe alarm output will turn OFF in alarm (the same state as the power-down state). A non-failsafe alarm output will turn ON in alarm. Alarm outputs must be separately enabled.

Alarm control of the output will take precedence over direct control when the High/Low Alarm Output Enable box is checked. Keep this in mind if you attempt to control the state of an alarm output directly, as the module will seek to maintain the correct output state relative to the alarm condition and alarm mode, each time it scans the input. How-

ever, this does not apply for input signals within the deadband region. If the input is within the deadband region, the discrete output state can be controlled directly, but direct control of an alarm output is not recommended.

There are three methods of detecting an alarm: the output status LED can be used to indicate a transfer to the alarm state, a global limit exceeded flag will be set in the Module Status Register, and a high and/or low limit flag will be set in the Channel Status Register. The Test Page of this software program will also report the alarm status for the module and an input channel.

**Watchdog Output Reset Value:** This selection determines the state the output will be automatically toggled to following a watchdog timeout. Select “ON” or “OFF” as required. Watch-dog timer control of the output will take precedence over alarm and direct control.

### Writing Your Configuration

After making your General and Alarm Configuration selections, you must download the new settings as follows:

Select **Module-Download Configuration** to write your configuration to the module.

### Module

- [Upload Configuration](#)
- [Download Configuration](#)

Note that you can select Module-Upload Configuration to retrieve the module's current alarm configuration and calibration, or to review and verify its configuration. Configuration data is stored in non-volatile memory within the DI-900MB module.

The next section covers testing of your configuration. If you have made changes to any of the module configuration screens, be sure to down-load your changes to the module prior to invoking any of the test or calibration pages.

### Testing Your Configuration

The “Test” portion of this program allows you to monitor polling, module status flags, read input values, reset the module, and control or monitor outputs.

**CAUTION:** If you have made changes to module configuration data screens but have not already downloaded those changes to the module, then selecting this page may change some of your software selections to match those obtained from polling the module. Always download your changes to the module before invoking the Test or Cal pages.

### Test Operation

Click on the “Test” property sheet tab to test the configuration just written to your module and a screen similar to the one at the right will be displayed (Model DI-913MB Test screen shown).

The flashing green Status lamp next to “Polling Status” indicates the software is communicating with the module and polling its I/O. Polling is automatic when this screen is displayed and turns off if another screen is selected. Note that a watchdog timeout will never occur if you are viewing this screen as it continuously polls the I/O.

The graphic simulation of the module LED's reflect the current LED status of the module.

You can reset the module by clicking the “Reset” button (same effect as power-on reset). Note that a module will exit the Default Mode following a reset. New address, baud rate, and parity settings will take effect immediately follow-

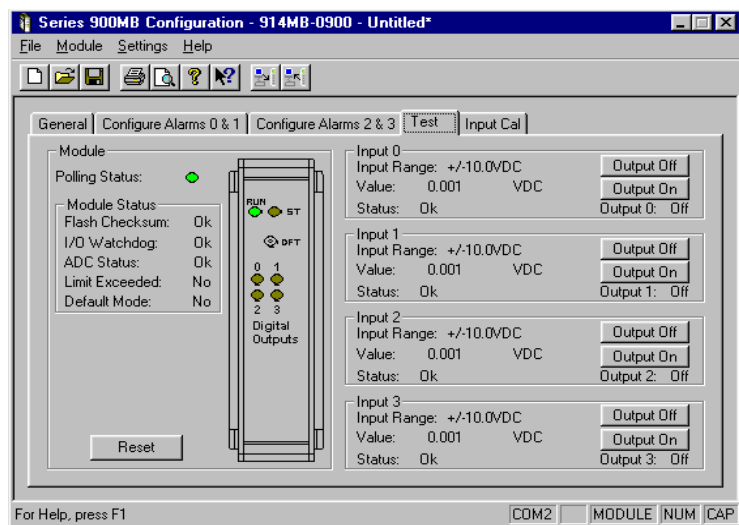

ing a reset-to continue communications following reset, make host software adjustments accordingly via the Settings pull-down menu.

For each input, the current selected input range, input value (“Value:”), and input status is indicated. The output states are also indicated. You may also turn the outputs On/Off by pressing the Set Output and Clear Output buttons (assuming they are not already enabled as alarm outputs). Keep in mind that alarm control of the output has priority over direct control (if enabled) and will seek to maintain the correct output state relative to the input level each time the input is scanned.

Clearing a watchdog timeout by initiating I/O with a module that has timed out will not automatically return the digital outputs to their pre-timeout state. It simply returns control of the output state to the alarms, or to the operator via manual control. Watchdog timeout control of the output has the highest priority (if enabled), followed by alarms (if enabled), with manual control of the outputs having the lowest priority.

**NOTE:** The module always returns measurements in scaled percent-of-span units with  $\pm 20000$  representing  $\pm 100\%$ . Scaling to input signal engineering units is done via this software for the convenience of display. Keep this in mind when using other software packages to interrogate a module.

Do not leave unused inputs floating or you may experience increased measurement noise and slower updates. It is recommended that you short unused inputs by applying a jump wire between IN+ & IN-.

### ***Print Your Configuration***

If you wish to document your transmitter configuration, then select **File-Print** to get a two page printout of all of your selected configuration parameters.

### ***Saving Your Configuration***

You should select **File-Save As** to save your configuration file to disk and give it a new file name.

Use **File-Save** to save the current file without renaming it.

Note that the currently loaded configuration file name is indicated at the top of the screen to the right of the model number.

In the event that you lose a configuration file, you can always upload it from the module via **Module-Upload Configuration**.

Now wasn't that easy! That's all there is to using the Configuration software to configure your module. The module is now ready for installation in the field.

Note that the configuration process will vary slightly for other model types.

The next section covers calibration of your inputs. Note that calibration has already been done at the factory and adjustment is not generally required. However, periodic re-calibration may be performed to correct for component aging, or as part of your company's maintenance requirements.

## Module Calibration

The calibration process is greatly simplified using the controls of the Modbus Configuration Software as described here.

**CAUTION:** If you have made changes to module configuration data screens but have not already downloaded those changes to the module, then selecting this page may change your software selections to match those obtained from polling the module. Always download your changes to the module before invoking the Test or Cal pages.

**Note:** Calibration of all supported input ranges has already been done on your module at the factory. Recalibration is normally not required, except as necessary to correct for long term component aging or to satisfy your company's maintenance requirements.

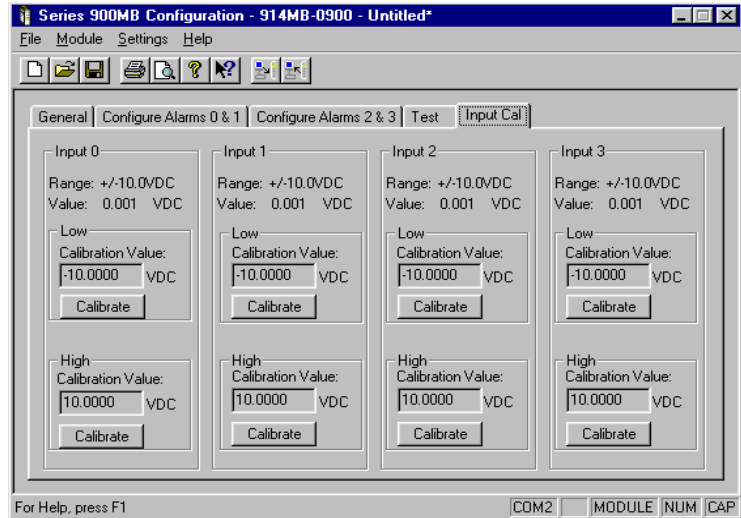

This portion of the program will allow you to calibrate the nominal input ranges of your module.

For best results, you will need a precision input signal source capable of reproducing the nominal input range endpoint signals at least as accurate as the module itself. Always allow the module to warmup prior to input calibration.

### Module Input Calibration

1. Click on the Input Calibration property sheet tab to display the screen shown at right (your screen may be slightly different according to your model and selected input range).

Note that Module-Upload Configuration will recall the module's current calibration for review or to make minor adjustments.

After upload, the current Low and High calibration values will be indicated in the Calibration Value fields. These correspond to the nominal input range endpoint signals of the selected input range. Uploading first will help prevent miscalibration if the input range set at the module is different than that selected via this software.

2. Adjust your input signal to precisely match the Low Calibration Value field entry. Observe proper polarity.
3. If the current input value indicated in the "Value:" field does not precisely match the low input signal value and the externally applied low endpoint signal level, press the Low "**Calibrate**" button to set the Low Calibration Value. After a moment, the value indicated should match the Low Calibration Value.
4. Next, adjust your input source to precisely match the High Calibration Value field entry. Observe proper polarity.
5. If the current input value indicated in the "Value:" field does not precisely match the high input signal value and the externally applied high endpoint signal level, press the High "**Calibrate**" button to set the High Calibration Value. After a moment, the value indicated should match the High Calibration Value.
6. Repeat steps 1-5 for each of the other input channels, as required.

**Please Note:**

Calibration points are restricted to the current selected input range endpoint values. Be sure to precisely match these levels via your input signal source. For example, the  $\pm 10\text{V}$  input range should use  $-10.000\text{V DC}$  as its low calibration point, and  $+10.000\text{V DC}$  as its high calibration point. Failure to use calibration points other than the current input range endpoints will result in measurement error.

It is a good idea to allow the module to warmup several minutes prior to calibration.

For best results, you should always calibrate the low value first before the high value.

The module uses scaled percent-of-span units with  $\pm 20000$  representing  $\pm 100\%$ . Scaling to input signal units is done for the convenience of this software. Keep this in mind when using other software to interrogate a module.

Refer to Drawing Electrical Connections (4501-855) at the back of this manual for example input connections.



# 7. Block Diagrams and Schematics

## Theory of Operation

Refer to Simplified Schematic (4501-853) and Functional Block Diagram (4501-854) to gain a better understanding of the circuit. Note that these transmitters will accept up to four process current or voltage input signals, and provide network commands to configure the module, monitor the inputs, and control the outputs. A multiplexer is used to connect each input channel to the A/D converter. The A/D converter then applies appropriate gain to the signal, performs analog-to-digital conversion, and digitally filters the signal. The digitized A/D signal is then transmitted serially to a microcontroller using optical isolators. The microcontroller completes the transfer function according to the input type and its embedded program. The microcontroller also compares the signal value to the limit value if the alarm function is used and completes all necessary alarm functionality per its embedded program. I/O lines of the microcontroller also switch the outputs ON/OFF, as required. The UART of the microcontroller sends/receives its I/O signals to the network via an optically isolated RS485 transceiver. Embedded configuration and calibration parameters are stored in non-volatile memory integrated within the micro-controller. New module functionality can be downloaded via the host running the Modbus Configuration Software, or other compatible Modbus software along the network. A wide input switching regulator (isolated flyback mode) provides isolated power to the various I/O circuits. Refer to Functional Block Diagram (4501-854) for an overview of how the software configuration variables are arranged.

## Simplified Schematic (4501-853)

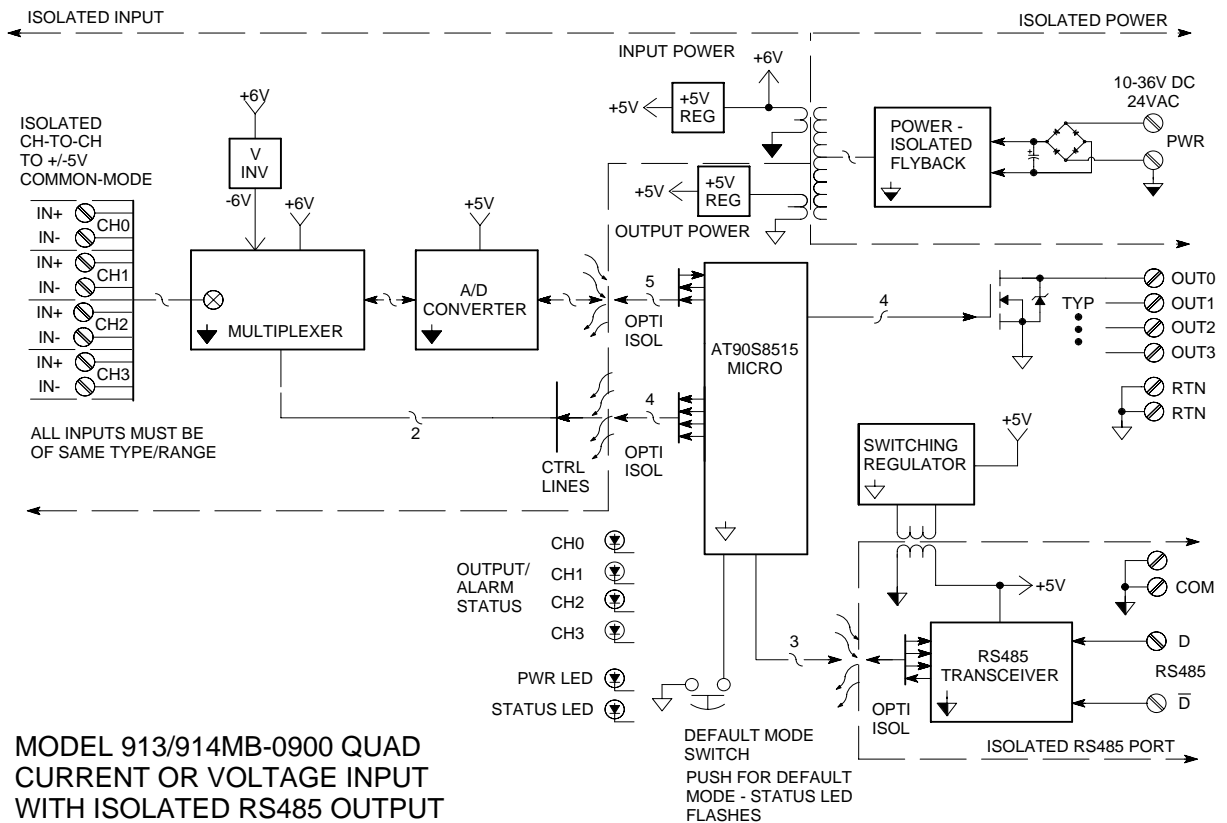

4501-853A

## Functional Block Diagram (4501-854)

### MODEL: 913MB-0900 AND 914MB-0900 TRANSMITTER FUNCTIONAL BLOCK DIAGRAM

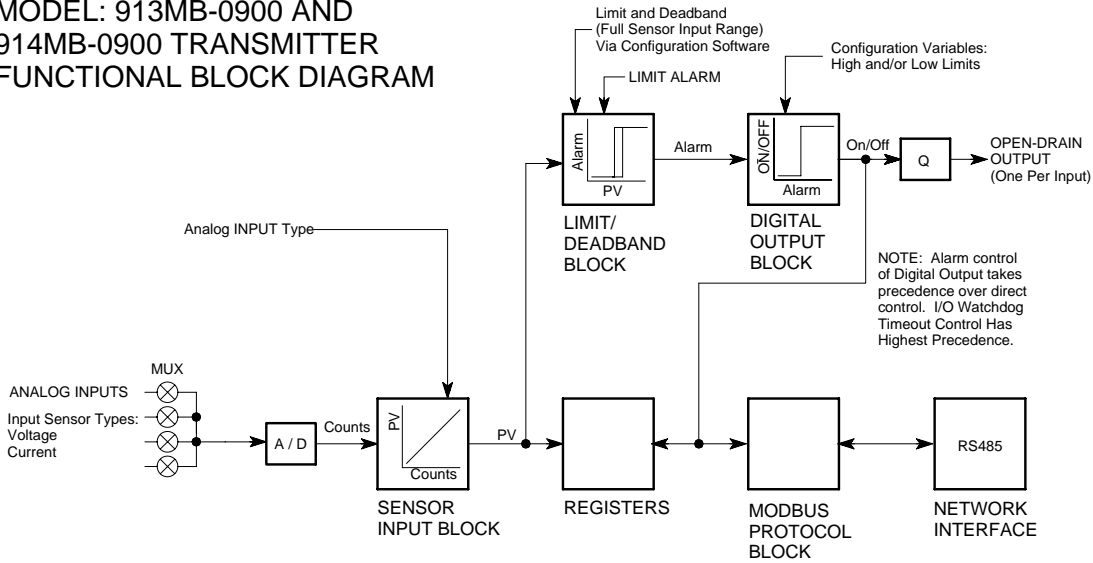

4501-854A

## Network Connections (4501-805)

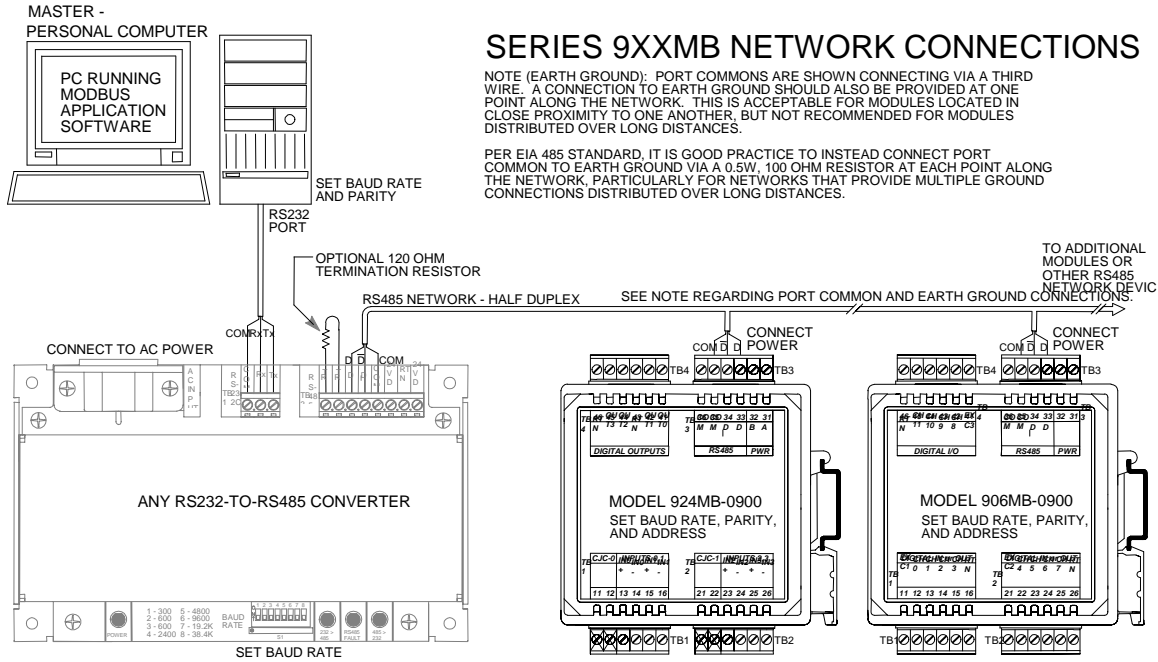

4501-805B



# Electrical Connections (4501-855)

## ELECTRICAL CONNECTIONS MODEL 913MB-0900 AND 914MB-0900

### INPUT CONNECTIONS

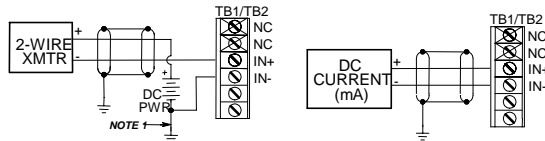

### 2-WIRE TRANSMITTER (913MB) DC CURRENT INPUT (913MB)

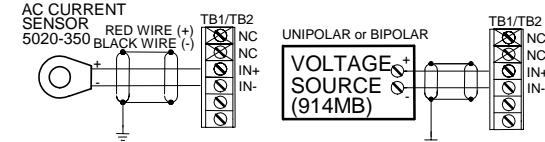

### AC CURRENT SENSOR INPUT (913MB)

### DIGITAL OUTPUT CONNECTIONS

POSSIBLE VARIATIONS - CURRENT SINKING DC APPLICATIONS ONLY

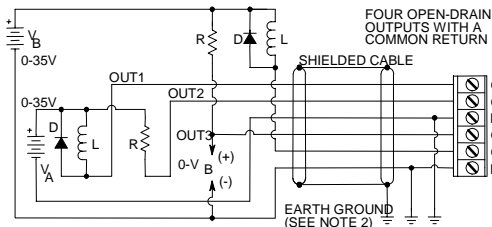

FOR DC-POWERED INTERPOSING RELAY CONNECTIONS SEE DRAWING 4501-807

NOTE 1: THIS GROUND CONNECTION IS RECOMMENDED FOR BEST RESULTS. IF SENSORS ARE INHERENTLY CONNECTED TO GROUND, USE CAUTION AND AVOID MAKING ADDITIONAL GROUND CONNECTIONS WHICH COULD GENERATE GROUND LOOPS AND MEASUREMENT ERRORS.  
NOTE 2: RETURNS SHOULD BE CONNECTED TO EARTH GROUND AT THE SAME POINT TO AVOID CIRCULATING GROUND CURRENTS.  
NOTE 3: EXTERNAL PULLUP RESISTOR (USER SUPPLIED).  
NOTE 4: RS485 PORT COMMON SHOULD CONNECT TO EARTH GROUND AT ONE POINT.

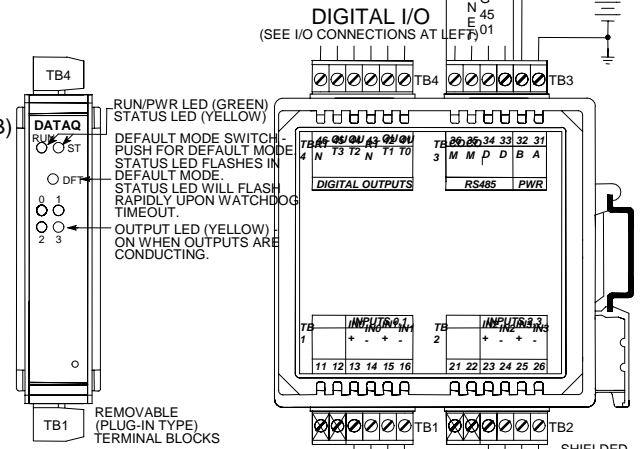

WARNING: FOR COMPLIANCE TO APPLICABLE SAFETY AND PERFORMANCE STANDARDS, THE USE OF SHIELDED CABLE IS RECOMMENDED AS SHOWN. ADDITIONALLY, THE APPLICATION OF EARTH GROUND MUST BE IN PLACE AS SHOWN IN THIS DRAWING. FAILURE TO ADHERE TO SOUND WIRING AND GROUNDING PRACTICES MAY COMPROMISE SAFETY AND PERFORMANCE.

SAFETY GUIDELINES MAY REQUIRE THAT THIS DEVICE BE HOUSED IN AN APPROVED METAL ENCLOSURE OR SUB-SYSTEM, PARTICULARLY FOR APPLICATIONS WITH VOLTAGES GREATER THAN OR EQUAL TO 75VDC/50VAC.

4501-855A

# Interposing Relay Conn. & Contact Pro. (4501-856)

## INTERPOSING RELAY CONNECTIONS MODEL 913MB-0900 AND 914MB-0900

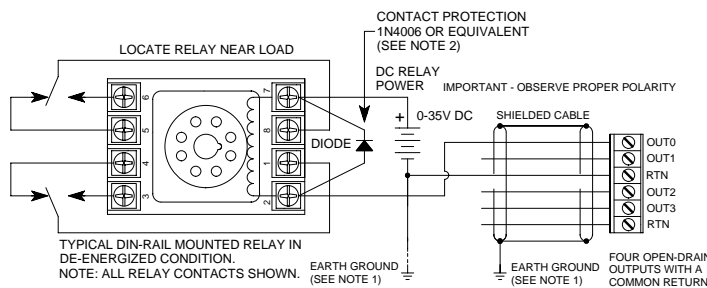

NOTE 1: RETURNS SHOULD BE CONNECTED TO EARTH GROUND AT THE SAME POINT TO AVOID CIRCULATING GROUND CURRENTS.  
NOTE 2: DIODE ADDED LOCAL TO INDUCTIVE LOAD TO SHUNT THE REVERSE EMF THAT IS GENERATED WHEN CURRENT THROUGH THE INDUCTOR (RELAY COIL) IS TURNED OFF.

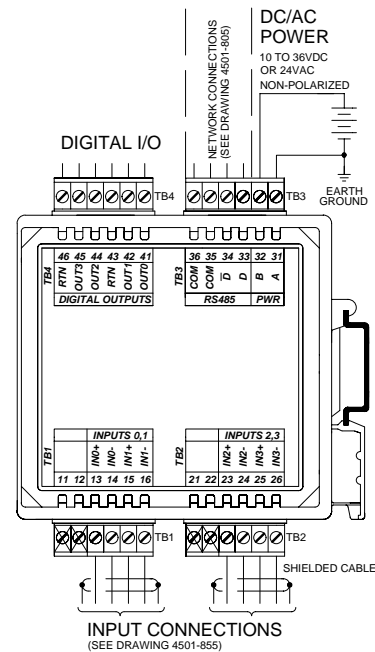

4501-856A

## Enclosure Dimensions (4501-857)

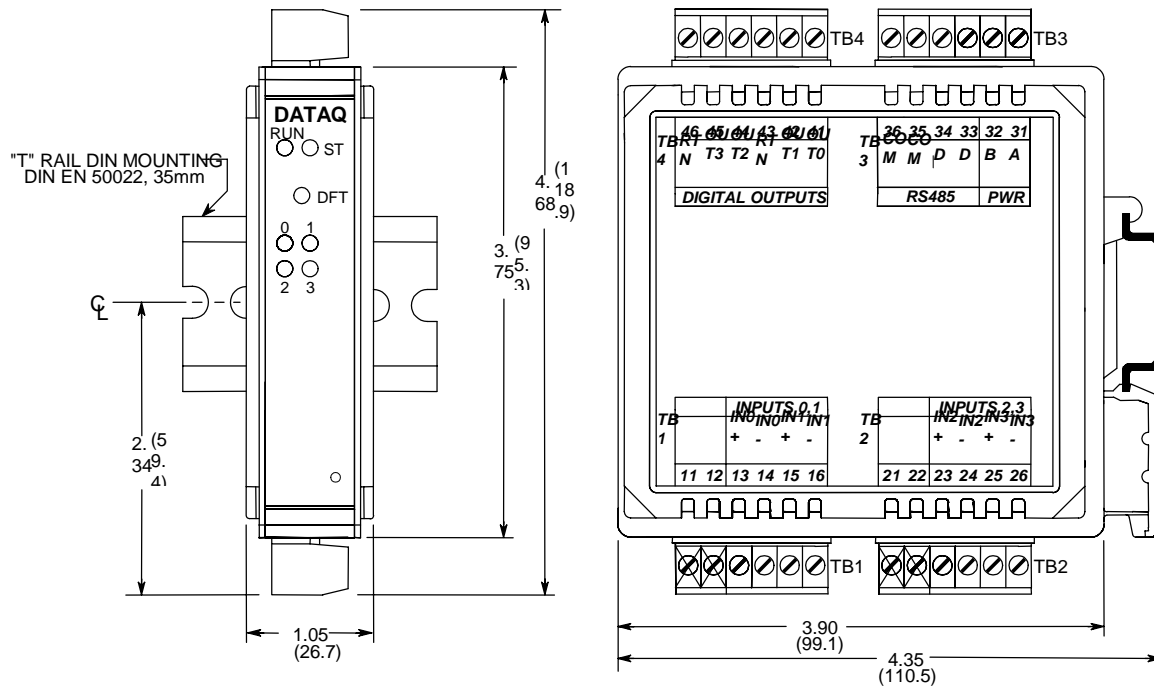

NOTE: ALL DIMENSION ARE IN INCHES (MILLIMETERS)

### SERIES 913MB/914MB ENCLOSURE DIMENSIONS

4501-857A

# 8. Accessories

## Series DI-900MB Software Interface Package (Model 100969)

The Software Interface Package combines the DI-900MB Configuration Software, RS-232 to RS-485 Serial Converter, Interface Cable, and Instructions, into a complete kit for interfacing with Series DI-900MB I/O Modules.

### ***DI-900MB Configuration & Control Software***

Series DI-900MB modules are configured with this user-friendly Windows 95/98<sup>®</sup> or NT<sup>®</sup> Configuration Program. Optionally, any software that supports the Modbus/RTU protocol may be used to configure and control Series DI-900MB modules, but the use of this software makes getting started easier. All module functions are programmable and downloadable to the modules via this software. The software also includes on-line help. Non-volatile memory provides program and configuration storage within the module.

### ***RS-232 to RS-485 Serial Adapter***

This device is a non-isolated, port-powered, signal converter for communication between the RS-232 serial port of a personal computer and the RS-485 network interface of Series DI-900MB I/O Modules. It is used in conjunction with the DI-900MB Configuration Software for simple reconfiguration, testing, and troubleshooting of Series DI-900MB I/O modules. As a port-powered device, it is not intended for driving fully loaded RS-485 networks over long distances, and does not have sufficient power to drive terminated networks. The adapter has DB-9F connectors at both ends and plugs directly into the common DB-9M serial port connector of most personal computers. The module is connected to the RS-485 side of this adapter via a separate interconnecting cable (see Interface Cable described below).

### ***Interface Cable***

This 3-wire cable is used to connect the RS-485 side of the Serial Adapter to the RS-485 network terminals of Series DI-900MB modules. This cable is 8 feet long and has a DE-9M connector on one end, and three stripped and tinned wires on the other end. The wires are labeled A, B, and C for connection to the module D, Dbar, and COM terminals, respectively.

## Isolated Signal Converter (Models 100974 and 100975)

This unit provides an isolated interface between the host PC's RS-232 port and RS-485 Modbus network devices. Signal conversion is bidirectional with operation that is transparent to all devices. The RS-485 network supports up to 32 devices (including the Signal Converter) across 4000 foot distances. Installation of additional network devices or extending the distance requires the Network Repeater described below. Optional 115V AC Power (Model 100974) or 230V AC Power (Model 100975). Power cord included. The Model Number 100976 connects the PC's RS-232 port to the Isolated Signal Converter.

## Isolated Network Repeater (Models 100977 and 100978)

This unit isolates and boosts RS-485 signals to extend communication distances or increase the number of devices on the network. Each Repeater permits the addition of a network branch with up to 32 devices (including the Network Repeater) and will transmit RS-485 signals another 4000 feet. Operation is transparent to all devices and no hand-shaking is required. Two terminal blocks are provided for 120 ohm resistors to terminate both ends of the network branch. Optional 115V AC Power (Model 100977) or 230V AC Power (Model 100978).

## AC Current Sensor (Model 100973)

For Use With Current Input Module DI-913MB. This optional sensor is an accurate toroidal instrument transformer used to convert a sinusoidal 50-60Hz AC current signal into a low level DC milliampere signal of 0 to 11.17mA. The

input AC current range is a simple function of the number of turns placed through the toroid as shown in the Table below. This sensor is isolated and requires no calibration or adjustment. When used with a DI-913MB module, it provides redundant input isolation and may facilitate input-to-input isolation of four channel units.

**AC Current Sensor Turns & Range**

AC Current Input Range	Primary Turns	Sensor Output (Red/Black Wires)
0 to 20A AC	1	0 to 11.17mA DC
0 to 10A AC	2	0 to 11.17mA DC
0 to 5A AC	4	0 to 11.17mA DC
0 to 2A AC	10	0 to 11.17mA DC
0 to 1A AC	20	0 to 11.17mA DC

The output wires of this sensor are polarized with red as (+) plus and black as (-) minus. Normally these output wires are attached to one end of a user supplied cable while the other end connects to the DI-913MB’s process current input terminals.

**Input Burden:** A function of the wire gauge resistance used for primary turns (the current carrying wire being monitored).

**AC Current Sensor to Transmitter Wiring Distance:** 400 feet maximum for 18 gauge wire. Other wire gauges can be used as long as the resistance of both wires is less than 5Ω

**Input Overload:** The AC current sensor will withstand overload conditions as follows:

- 20 times full scale for 0.01 seconds.
- 10 times full scale for 0.1 seconds.
- 5 times full scale for 1.0 second.





DATAQ Instruments, Inc.  
241 Springside Drive  
Akron, Ohio 44333  
Telephone: 330-668-1444  
Fax: 330-666-5434  
E-mail: [support@dataq.com](mailto:support@dataq.com)

### Direct Product Links

(click on text to jump to page)

[Data Acquisition](#) | [Data Logger](#) | [Chart Recorder](#) | [Thermocouple](#) | [Oscilloscope](#)